

1/06 (CORNICE PORTION OF WALL SECTION)

TYPICAL CONNECTION AT CORNICE

2/13b BRICK OPTION

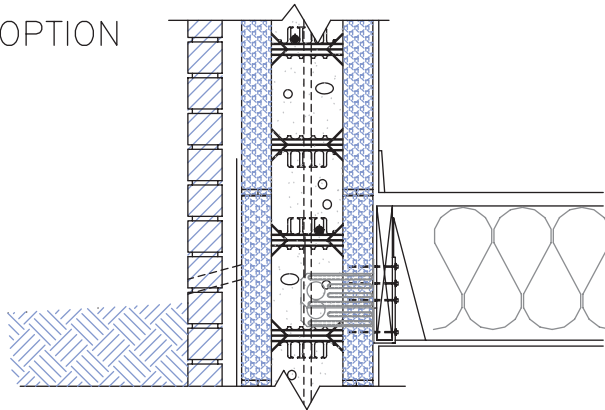

1/14

TYPICAL FLOOR INTERSECTION

ALSO SEE ALTERNATE SECTION DETAIL 2-14

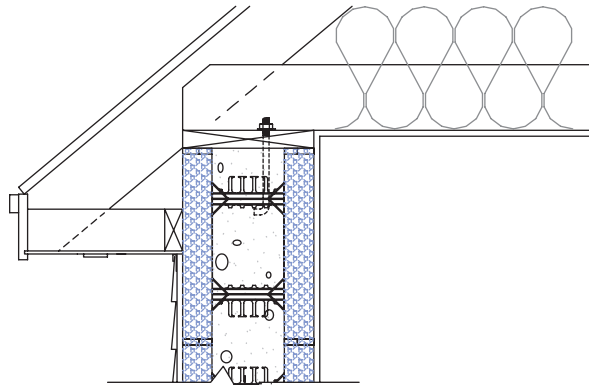

1/08 (CORNICE PORTION OF WALL SECTION)

TYPICAL CONNECTION AT CORNICE

1/13b SIDING OPTION

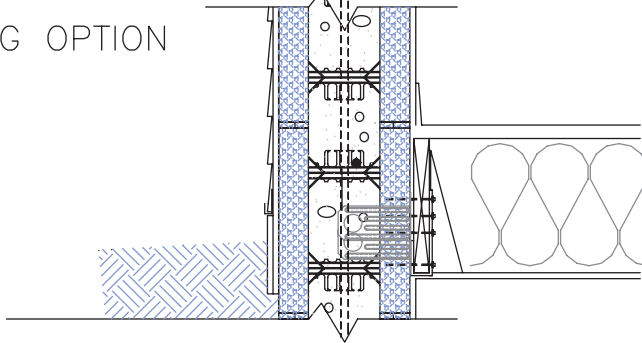

1/14

TYPICAL FLOOR INTERSECTION

ALSO SEE ALTERNATE SECTION DETAIL 2-14

NOTE:

DUE TO VARIATIONS IN SELECTED PRINTER SETTINGS, NOTED SCALES MAY NO LONGER BE APPLICABLE



9705 N. BROADWAY EXTENSION, SUITE 200, OKLAHOMA CITY, OK 73114  
OFFICE: 405-840-3386 | TOLL FREE: 866-222-2575 | FAX: 831-597-0792  
BUILDBLOCK.COM

WALL DETAIL W/SILL PLATE & SLOPE ROOF

DATE/REV	11-17-09	SCALE	NTS	DETAIL SHEET
----------	----------	-------	-----	--------------

NOTES	
-------	--

CONSTRUCTION SHALL BE IN ACCORDANCE WITH ALL APPLICABLE LOCAL AND NATIONAL CODES. ALL DRAWINGS ARE SUBJECT TO CHANGE WITHOUT NOTICE.

**13B**