

CORNER REINFORCEMENT

ZIP-TIE THE WEB TIES CUT OFFS TOGETHER TO REINFORCE THE CORNER. BOND THE CUT EDGES TOGETHER WITH FOAM2FOAM OR SIMILAR LOW EXPANDING FOAM ADHESIVE.

ADEQUATE BRACING AND STRAPPING IS REQUIRED FOR ALL FIELD FABRICATED CORNERS. LARGER BLOCK CORES REQUIRE ADDITIONAL BRACING AND STRAPPING ON OUTSIDE CORNER CUTS. CONTACT BUILDBLOCK TECHNICAL SUPPORT FOR MORE INFORMATION.

HOW TO FIELD FABRICATE A CORNER

1. MARK THE DIMENSIONS SHOWN ON THE BLOCK.
2. USING A STRAIGHT EDGE, DRAW A LINE ACROSS THE FORM TO SERVE AS A GUIDELINE.
3. USE A HOT KNIFE OR HANDY SAW TO CUT THE FORM.
4. FLIP ONE OF THE HALVES AND ALIGN THE CUT EDGES TO MAKE THE MITERED CORNER.
5. FOAM GLUE THE EDGES, ZIP-TIE THE WEB TIES CUT OFFS, AND ADD STRAPPING AND BRACING AS REQUIRED.

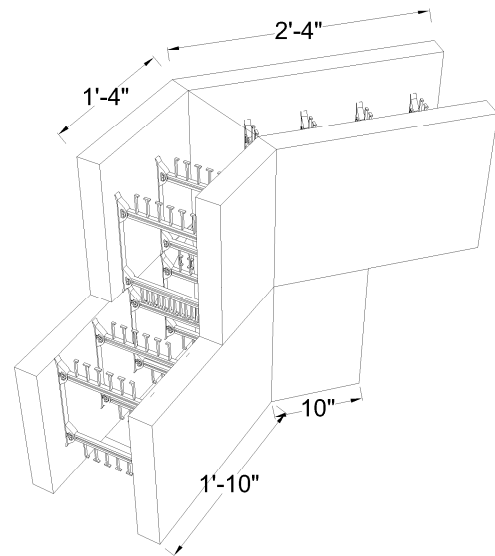

FIELD CUT CORNERS CAN BE MADE EASILY USING THESE DIMENSIONS. THE CUTS ARE DESIGNED TO ALLOW SUFFICIENT RUNNING BOND FOR THE FORMS. THESE DIMENSIONS DO NOT MATCH FACTORY CORNERS. CUTS SHOULD BE MADE WITH THE MOST ACCURATE SAW AVAILABLE. FIELD MITERS SHOULD BE REINFORCED WITH WOOD OR METAL STRAPPING, AND BRACED ADEQUATELY. SEE INSTALLATION MANUAL FOR MORE DETAIL ON STRAPPING AND BRACING.

DATE / REVISION / BY	7-1-23 / 1 / AQ
SCALE	NTS
FILE NAME	1.109 - BB1000