

CITY OF LOS ANGELES

CALIFORNIA



ERIC GARCETTI
MAYOR

BOARD OF
**BUILDING AND SAFETY
COMMISSIONERS**

VAN AMBATIELOS
INTERIM PRESIDENT

E. FELICIA BRANNON
JOSELYN GEAGA-ROSENTHAL
GEORGE HOVAGUIMIAN
JAVIER NUNEZ

DEPARTMENT OF
BUILDING AND SAFETY
201 NORTH FIGUEROA STREET
LOS ANGELES, CA 90012

RAYMOND S. CHAN, C.E., S.E.
GENERAL MANAGER

FRANK BUSH
EXECUTIVE OFFICER

BuildBlock Building Systems, LLC
9705 N. Broadway Ext.
Oklahoma City, Oklahoma 73114

RESEARCH REPORT: RR 25995

Attn: Rebecca Downey
(405) 840-3386

REEVALUATION DUE
DATE: February 1, 2020
Issued Date: March 1, 2018
Code: 2017 LABC

GENERAL APPROVAL – Renewal and Clerical Modification- Buildblock® Insulating Concrete Forms (ICFs)

DETAILS AND USES

BuildBlock® Insulating Concrete Forms (ICFs) are used as stay-in-place formwork for structural concrete, load bearing and non-load bearing, below-grade and above-grade walls. The forms are used in construction of reinforced concrete beams, lintels, exterior and interior walls, and foundation and retaining walls. The forms remain in place after placement and curing of concrete and must be covered with approved interior and exterior finish material. The forms are limited to use in buildings of combustible construction only.

BuildBlock Building Systems, LLC, forms are manufactured in Pardeeville, Wisconsin; Colorado Springs, Colorado; Elkhart, Indiana; West Brookfield, Massachusetts; Nixa, Missouri; Orlando, Florida; McFarland, California; and Post Falls, Idaho, under quality control programs with inspections conducted by Intertek Testing Services NA, Ltd. (AA-690).

DESCRIPTION

General:

The ICFs consist of two expanded polystyrene (EPS) foam plastic panels separated by injection-molded polypropylene cross-ties which are partially embedded into the EPS panels. The polypropylene cross-ties maintain the EPS panel facings at a fixed clear distance of 4 inches (102 mm), 6 inches (152 mm) or 8 inches (203 mm) to create overall form widths of 9 inches (229 mm), 11 inches (279 mm) or 13 inches (330 mm). The form units have a preformed interlocking mechanism along the top and bottom edges, to facilitate interlocking and stacking. In addition to the standard forms, 45-degree angle corners, 90-degree angle corners and ledge forms used to

RR 25995
Page 1 of 13

construct corbels that serve as ledgers to support exterior brick veneers are available. See Figures 1 through 4 for illustrations of the forms.

Material:

Panels: The EPS panels are 16 inches (406 mm) high, 48 inches (1219 mm) long and 2 ½ inches (64 mm) thick. The panels are manufactured by injecting and expanding polystyrene beads into molds. The resulting EPS foam plastic complies with ASTM C578 as Type II, with a nominal density of 1.5 pcf (24.1 kg/m³). The EPS foam plastic has a flame-spread index of 25 or less and a smoke-developed index of 450 or less when tested in accordance with ASTM E84.

Polypropylene Cross-Tie: The polypropylene cross-ties, spaced 6 inches (152 mm) on center, connect the EPS foam plastic panels at a fixed clear distance. The cross-tie consists of a flange portion that is embedded in the foam plastic panel during the foam plastic molding process, and a web portion that connects the two flanges and therefore the two foam plastic panels. The cross-tie has openings to permit concrete to flow through, and has slots to support horizontal steel reinforcing bars. The plastic flange of the cross-tie is recessed ½ inch (12.7 mm) below the EPS surface and is used for attachment of exterior and interior finish materials. The flange of the cross-tie is 1 ½ inches wide by 15 inches high by 3/16 inches thick (38 mm by 381 mm by 4.8 mm). The cross-tie also includes a web hard point area which is denoted by a “BB” on the ICF and consists of a double reinforced section of the flange that is spaced 8 inches (203 mm) on center vertically and 6 inches (152 mm) on center horizontally.

Concrete: Concrete must be normal-weight concrete complying with the applicable code, and must have a maximum aggregate size of ¾ inch (19 mm) and a maximum slump of 6 inches (152 mm). The maximum water-cementitious materials ratio must be 0.5, unless otherwise approved by the code official. Concrete must have a 28-day minimum compressive strength of 3,000 psi (20.7 MPa). Under the IRC, concrete must comply with IRC Sections R404.1.4 and R611.5.1

Reinforcement: Walls must be reinforced with deformed steel bars, having a minimum yield stress of 40 ksi (275 MPa) or 60 ksi (413 MPa) depending on structural design. The deformed steel bars must comply with Section 3.5.3.1 of ACI 318.

Other Components: Wood members in contact with concrete for plates of window and door framing must be treated with an approved wood preservative or be a naturally durable species, and must be attached with corrosion-resistant fasteners complying with Los Angeles Building Code, Section 2304.9.5. Materials other than wood, such as vinyl, or metal, are permitted for window and door framing if approved by the code official.

DESIGN AND INSTALLATION

General:

Design and installation of ICFs must comply with this report, the applicable code and the manufacturer’s published installation instructions. The manufacturer’s published installation instructions must be available at the jobsite at all times during installation.

Design:

Los Angeles Building Code (LABC): Concrete walls formed by the ICFs must be designed and constructed in accordance with LABC Chapters 16 and 19, as applicable. Footings and foundations must be designed and constructed in accordance with LABC Chapter 18.

Installation:

The ICFs and resulting concrete walls must be supported on concrete footing and foundations complying with LABC Chapters 18 and 19, as applicable. Placement of the form units must begin at a corner and proceed around the building perimeter. The amount, placement and spacing of reinforcing required must be determined for each project, based on the approved plans and the applicable code. Vertical rebar embedded in the footing must extend into the base of the wall system the minimum development length necessary for the compliance with Chapter 12 of ACI 318. Additional reinforcement around doors and windows must be described in the approved plans. Concrete quality, mixing and placement must comply with the applicable code. Window and door openings must be built into the form units, prior to the placement of the concrete, with wood, steel bucks or polyvinyl chloride plastic frames of the same dimensions as the “rough stud opening” specified by the window or door manufacturer. Wood ledgers must be attached to the concrete wall by removing the face shell of the form units, with the height of the removed portion being equal to the depth of the wood ledger. Wood plates must be anchored to the top of the concrete wall. Anchor bolts used to connect the wood ledgers, plates and framing for wall openings to the concrete must be cast in place, with the bolts sized and spaced, as required by the design and the applicable code. Details must be prepared to accommodate the specific job situation, in accordance with the applicable code and the requirements of this report, subject to the approval of the code official.

Interior Finish:

General: Form units exposed to the building interior must be finished with an approved 15-minute thermal barrier, such as minimum ½ inch-thick (12.7 mm) gypsum wall board complying with ASTM C36, placed with the long side vertical. The gypsum wall board must be attached to web-tie flanges with 1 5/8 inch-long (41 mm), No. 6, Type W, coarse-thread gypsum wall board screws spaced 16 inches (406 mm) on center vertically and 12 inches (305 mm) on center horizontally. The screws must penetrate a minimum of ¼ inch (6.4 mm) through the web-tie flange. Gypsum wall board joints must be taped and finished with joint compound in accordance with ASTM C840 or GA 216. See section 3.4.2 for installation details for crawl space applications without an ignition barrier on the interior face.

Attic and Crawl Space Installations: When the BuildBlock® ICFs described in this report are used as walls of attic or crawl spaces; an ignition barrier complying with section 2603.4.1.6 of 2017 Los Angeles Building Code or sections R316.5.3 and R316.5.4 of 2014 Los Angeles Residential Code is required except when all of the following conditions are met:

- Entry to the crawl space is only to service utilities, and no storage is permitted.
- There are no interconnected attic or basement areas.
- Air in the attic or crawl space is not circulated to other parts of the building.

- Attic ventilation is provided when required by LABC section 1203.2 or LARC section R408.1 as applicable
- Under-floor (crawl space) ventilation is provided that complies with LABC Section 1203.3 or LARC section R806, as applicable.

Exterior Finish:

Above Grade: The exterior surface of the ICF must be covered with an approved wall covering in accordance with the applicable code or a current evaluation report.

When wall covering is required to be attached to structural members, the wall covering must be attached to the flanges of the plastic cross-ties with fasteners described in Table 2 of this report of sufficient length to penetrate through the cross-tie flanges a minimum of ¼ inch (6.4 mm). The screws have an allowable withdrawal and lateral capacity as noted in Table 2. Screws may be placed in the BuildBlock (BB) flange hard point areas for additional fastening with withdrawal and lateral capacities as noted in Table 2. The flange hard point area is described as a double-reinforced section of the flange located every 8 inches vertically (203 mm) on center and every 6 inches horizontally (152 mm) on center.

The maximum fastener spacing must be designed to support the gravity loads of the wall covering and resist the negative wind pressures. The negative wind pressure capacity of the exterior finish material must be the same as that recognized in the applicable code for generic materials, or that recognized in a current evaluation report for proprietary materials and must not exceed the rated maximum withdrawal rating of the screws.

Foundation Walls:

The ICFs are permitted to be used as a foundation stem wall when supporting wood-framed or steel-framed construction, provided the structure is supported on concrete footings complying with the applicable code.

CONDITIONS OF APPROVAL

The BuildBlock Insulating Concrete Forms (ICFs) described in this report comply with, or are suitable alternatives to what is specified in the Los Angeles Building Code, subject to the following conditions:

1. Form units must be separated from the building interior with an approved 15-minute thermal barrier, except for crawl space construction as described above under attic and crawl space installation.
2. The fire rating of the ICF assemblies is beyond the scope of this approval.
3. Calculations showing compliance with the general design requirements of the code must be submitted to the code official for approval. The calculations and details must be

prepared by a registered design professional where required by code and approved by the structural plan check.

4. The maximum allowable pour rate of the forms shall be 4 feet per hour.
5. Form units are manufactured, identified and installed in accordance with this report and the BuildBlock® Insulating Concrete Forms published installation instructions. If there is a conflict between the manufacturers's published installation instructions and this report, this report governs.
6. Continuous inspection by Deputy Inspectors shall be provided for placement of reinforcing steel and concrete.
7. Termite protection in accordance with Section 2603.9 of the Los Angeles Building Code and Section R318.4 of the Los Angeles Residential Code shall be provided.
8. Specified compressive strength of concrete shall not be less than 3000 psi.
9. Materials used to damp-proof or waterproof basement walls must be specified by BuildBlock Building Systems, LLC and must comply with the applicable code or a current evaluation report. The materials must be compatible with the ICF foam plastic units and be free of solvents, hydrocarbons, ketones and esters that will adversely affect the EPS foam plastic panels. Damp-proofing, waterproofing and drainage requirements must comply with the applicable code. No backfill can be applied against the wall until the complete floor system is in place, unless the wall is designed as a freestanding wall that does not rely on the floor system for structural support.
10. Special inspection is required as noted in Los Angeles Building Code Section 1705 for placement of reinforcing steel and concrete, and for concrete cylinder testing. Special inspection, in accordance with Los Angeles Building Code Section 1705.1 and 1705.13, is required when an EIFS wall covering is applied. Duties of the special inspector must include verifying field preparation of materials, expiration dates, installation of components, curing components, and installation of joints and sealants.
11. Each package or pallet of BuildBlock® Insulating Concrete Forms must be labeled with the company name (BuildBlock Building Systems, LLC), address and telephone number; manufacturing location and date; the lot number and the name of the inspection agency (Intertek Testing Services NA Ltd.); and the evaluation report number.

DISCUSSION

The clerical modification is to update the report to the 2017 City of Los Angeles Building Code, and change the contact person and phone number.

BuildBlock Building Systems, LLC
RE: Buildblock® Insulating Concrete Forms (ICFs).

The report is in compliance with the 2017 City of Los Angeles Building Code.

The approval is based on tests in accordance with AC12, AC15, AC353, ASTM E2634

Data in accordance with the ICC-ES Acceptance Criteria for Stay-in-Place Foam Plastic Insulating Concrete Form (ICF) Systems for Solid Concrete Walls (AC353), dated October 2012 (editorially revised October 2013) and ASTM E2634-10 Standard Specification for Flat Wall Insulating Concrete Form (ICF) Systems.

This general approval will remain effective provided the Acceptance Criteria and Standards are maintained valid and unrevised with the issuing organization. Any revisions to the testing criteria and standards must be submitted to this Department, with appropriate fee, for review in order to continue the approval of the revised report.

This general approval of an equivalent alternate to the Code is only valid where an engineer and/or inspector of this Department has determined that all conditions of this Approval have been met in the project in which it is to be used.

Addressee to whom this Research Report is issued is responsible for providing copies of it, complete with any attachments indicated, to architects, engineers and builders using items approved herein in design or construction which must be approved by Department of Building and Safety Engineers and Inspectors.

QUAN NGHIEM, Chief
Engineering Research Section
201 N. Figueroa Street, Room 880
Los Angeles, CA 90012
Phone (213) 202-9816
Fax (213) 202-9942

DE
RR25740/Word 2010
R2/19/17
TLB1800035
1906.1/2603/703.2

APPENDIX – PROPERTIES, ALLOWABLE LOADS AND ASSEMBLY TABLES, TYPICAL DETAILS

TABLE 1 – PROPERTIES EVALUATED

PROPERTY	IBC SECTION	IRC SECTION
Physical properties	NA	R404.1.2.3.6.1 and R611.4.4
Surface Burning Characteristics	2603.3	R316.3
Fire resistance	703.2	R302.1
Exterior walls in Types I – IV construction	2603.5	NA
Attic and crawl space applications	2603.4.1.6 and 2603.10	R316.5.3, R316.5.4 and R316.6

TABLE 2 – THREE HOUR FIRE-RESISTANCE-RATED WALL ASSEMBLIES⁴

WALL TYPE	FORM WIDTH	THERMAL BARRIER ^{3,4}	STEEL REINFORCEMENT ¹
Bearing ^{1,2,3,4,5} Max load 5000 lbf/lin ft	11,13, 15 or 17 inches	½-inch gypsum wallboard fastened 12 inches oc in field and 6 inches oc at perimeter	Vertical - #5, 24 inches oc Horizontal - #5, 32 inches oc
Nonbearing ^{2,3}	11,13, 15 or 17 inches	½-inch gypsum wallboard fastened 12 inches oc in field and 6 inches oc at perimeter	Vertical - #5, 24 inches oc Horizontal - #5, 32 inches oc

For SI: 1 inch = 25.4 mm, 1 lbf/ft = 14.59 N/m

¹Steel reinforcement is the minimum required for the design loads given.

²Concrete must be normal-weight concrete [(150-155 lb/ft³) (2403-2483 kg/m³)] with a minimum 3000 psi (20 684 kPa) compressive strength.

³Fasteners to attach the gypsum wallboard thermal barrier must be 1-5/8-inch long No. 6, Type W, coarse-thread gypsum wallboard screws. See Section 4.3.1

⁴The wall assembly may be used as either an interior or exterior wall. When used as an interior wall, both sides of the form must be protected with gypsum wallboard.

⁵Design loads are based on 10-foot wall heights.

TABLE 3 – ALLOWABLE WITHDRAWAL AND LATERAL CAPACITIES OF FASTENERS IN CROSS-TIE FLANGES

FASTENER ¹	ALLOWABLE LOAD CAPACITY (lbf)	
	Lateral	Withdrawal
#2 square drive, 0.120-inch, fine thread screw having average 5 threads per inch placed at any point on the flange	56	24
#2 square drive, 0.120-inch, fine thread screw having 5? threads per inch placed at center of BB Hard Point ² location on the flange	56	33
No. 6, Type S, fine thread drywall screw placed at any point on the flange	54	31
No. 6, Type S, fine thread drywall screw placed at center of BB Hard Point ² location on the flange	81	66

BuildBlock Building Systems, LLC
 RE: Buildblock® Insulating Concrete Forms (ICFs).

For SI: 1 lb = 4.45 N, 1 inch = 25.4 mm

¹Fasteners must be of sufficient length to penetrate through the flange a minimum of ¼ inch.

²BB Hard Points are located at points marked “BB” on the forms, 4 inches from the top and bottom edges, at 6 inches on center horizontally. See Figure 1.

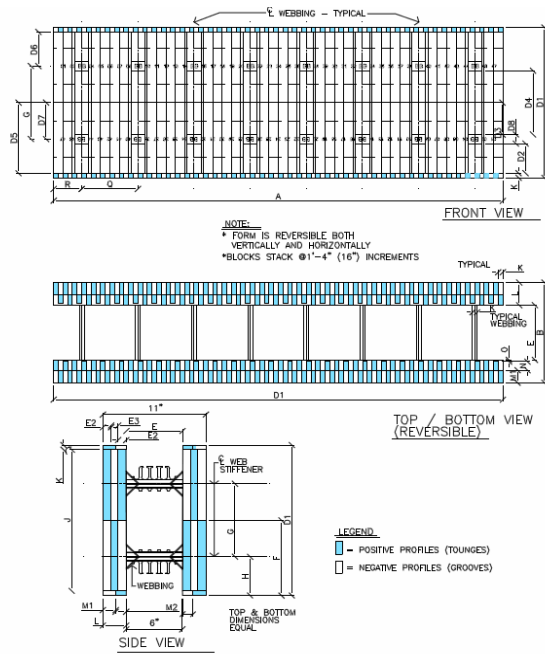

Dimensions (Imperial)	Straight Block Form Size (Core)				
	4"	6"	8"	10"	12"
A	4'-0"	4'-0"	4'-0"	4'-0"	4'-0"
B	9"	11"	13"	15"	17"
C					
D1	1' 4-1/2"	1' 4-1/2"	1' 4-1/2"	1' 4-1/2"	1' 4-1/2"
D2	3-1/4"	3-1/4"	3-1/4"	3-1/4"	3-1/4"
D3	3-1/2"	3-1/2"	3-1/2"	3-1/2"	3-1/2"
D4	7"	7"	7"	7"	7"
D5	7-3/4"	7-3/4"	7-3/4"	7-3/4"	7-3/4"
D6	3-3/4"	3-3/4"	3-3/4"	3-3/4"	3-3/4"
D7	4"	4"	4"	4"	4"
D8	1"	1"	1"	1"	1"
E	4"	6"	8"	10"	12"
E2	7/8"	7/8"	7/8"	7/8"	7/8"
E3	3/4"	3/4"	3/4"	3/4"	3/4"
F	8-1/4"	8-1/4"	8-1/4"	8-1/4"	8-1/4"
G	8"	8"	8"	8"	8"
H	4-1/4"	4-1/4"	4-1/4"	4-1/4"	4-1/4"
J	1' 3-1/2"	1' 3-1/2"	1' 3-1/2"	1' 3-1/2"	1' 3-1/2"
K	1/2"	1/2"	1/2"	1/2"	1/2"
L	2-1/2"	2-1/2"	2-1/2"	2-1/2"	2-1/2"
M1	1-3/8"	1-3/8"	1-3/8"	1-3/8"	1-3/8"
M2	1-1/8"	1-1/8"	1-1/8"	1-1/8"	1-1/8"
O	3/16"	3/16"	3/16"	3/16"	3/16"
Q	6"	6"	6"	6"	6"
R	3"	3"	3"	3"	3"

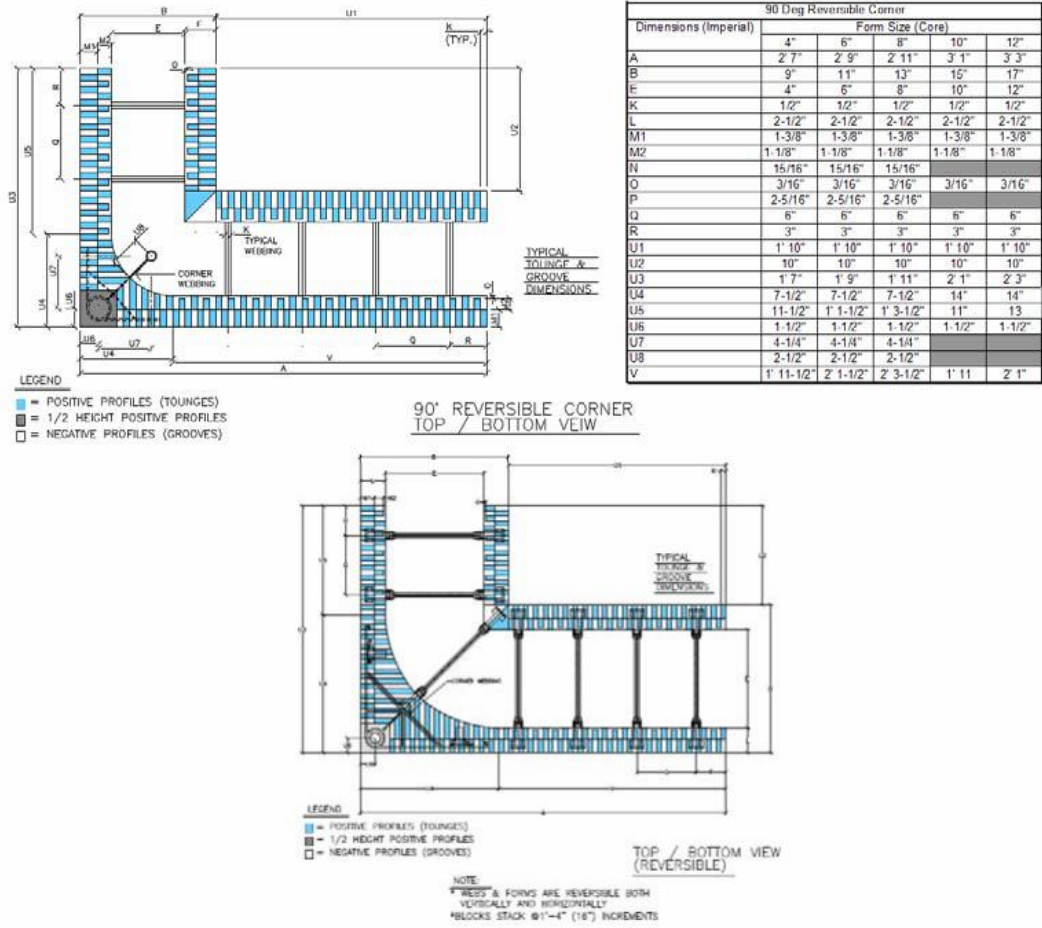
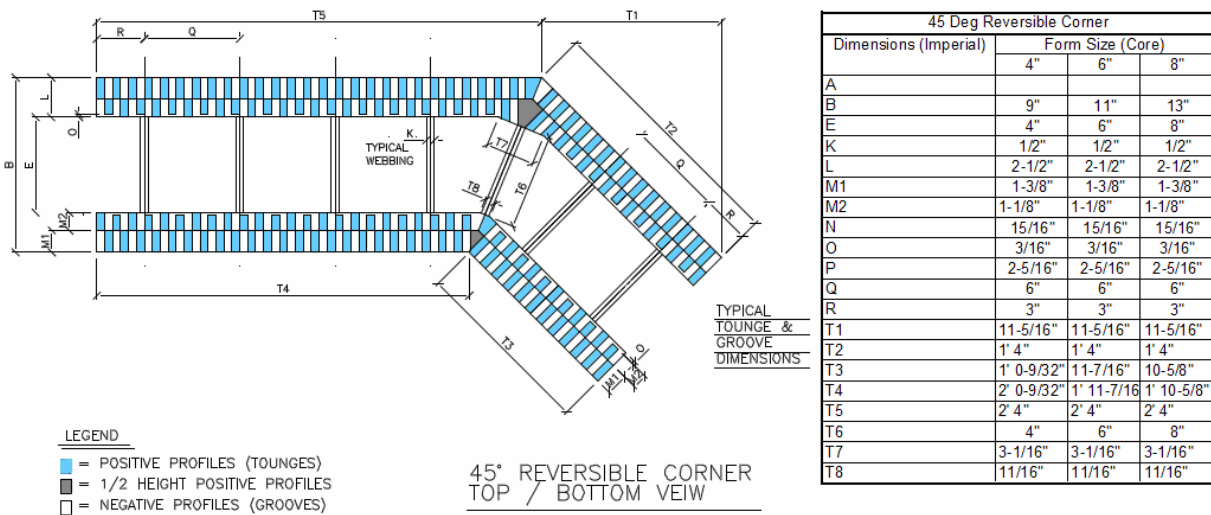

FIGURE 1 – BUILDBLOCK® AND BUILDLOCK® FORMS



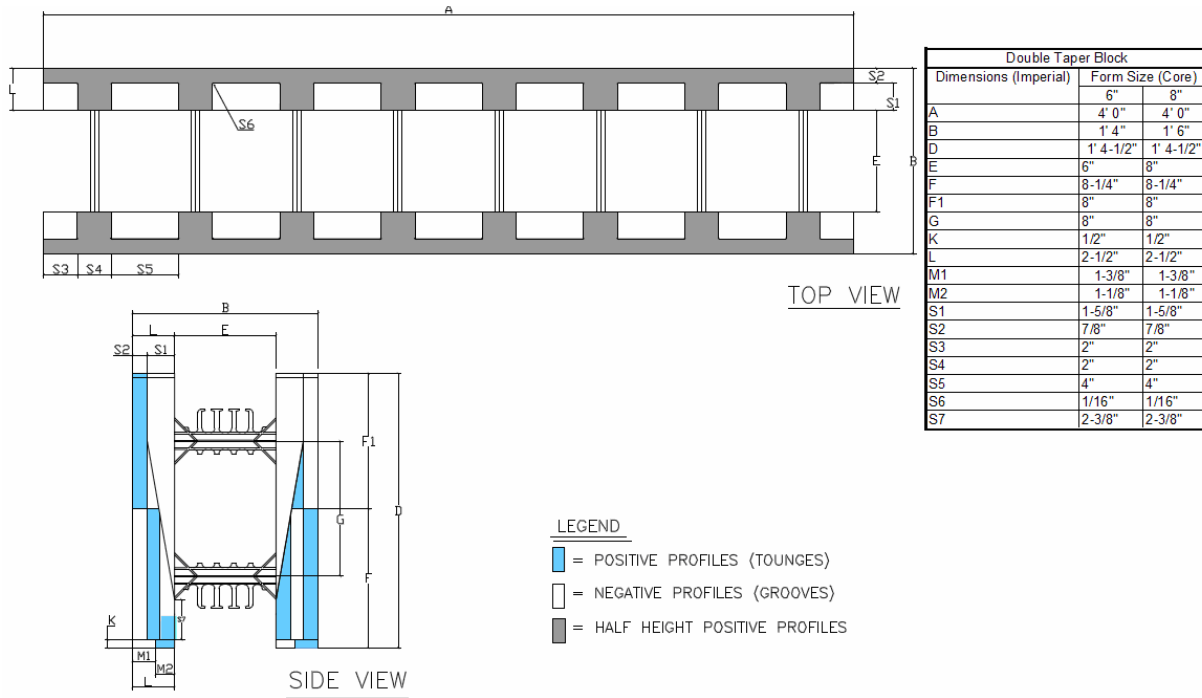
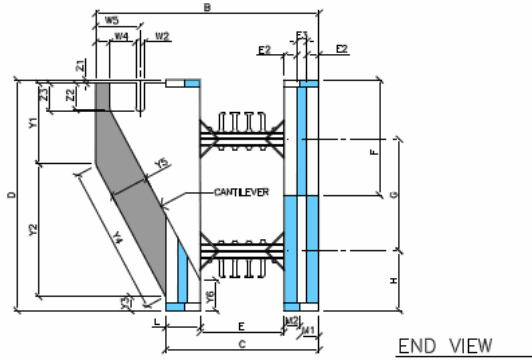
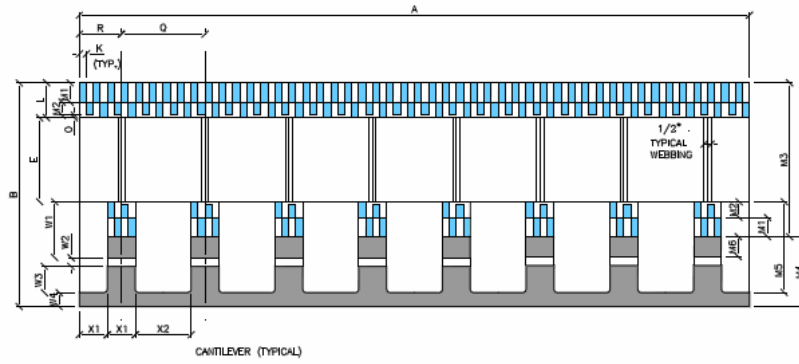

FIGURE 1 – BUILDBLOCK® FORMS (continued)



LEGEND
 ■ - POSITIVE PROFILES (TOUNGES)
 □ - NEGATIVE PROFILES (GROOVES)
 ▬ = BASELINE

Ledge Block		
Dimensions (Imperial)	Form Size (Core)	
	6"	8"
A	4' 0"	4' 0"
B	1' 4"	1' 6"
C	11"	13"
D	1' 4-1/2"	1' 4-1/2"
E	6"	8"
E2	7/8"	7/8"
E3	3/4"	3/4"
F	8-1/4"	8-1/4"
G	8"	8"
H	4-1/4"	4-1/4"
K	1/2"	1/2"
L	2-1/2"	2-1/2"
M1	1-3/8"	1-3/8"
M2	1-1/8"	1-1/8"
M3	11"	13"
M4	5"	5"
M5	6-1/2"	6-1/2"
M6	1-7/16"	1-7/16"
O	3/16"	3/16"
P	2-5/16"	2-5/16"
Q	6"	6"
R	3"	3"
W1	4"	4"
W2	5/8"	5/8"
W3	1-7/8"	1-7/8"
W4	1"	1"
W5	3-3/16"	3-3/16"
X1	2"	2"
X2	4"	4"
Y1	5-3/4"	5-3/4"
Y2	9-1/2"	9-1/2"
Y3	1"	1"
Y4	10-5/8"	10-5/8"
Y5	2-3/4"	2-3/4"
Y6	2-3/16"	2-3/16"
Z1	1/4"	1/4"
Z2	1-7/8"	1-7/8"
Z3	2"	2"

FIGURE 1 – BUILDBLOCK® FORMS (continued)

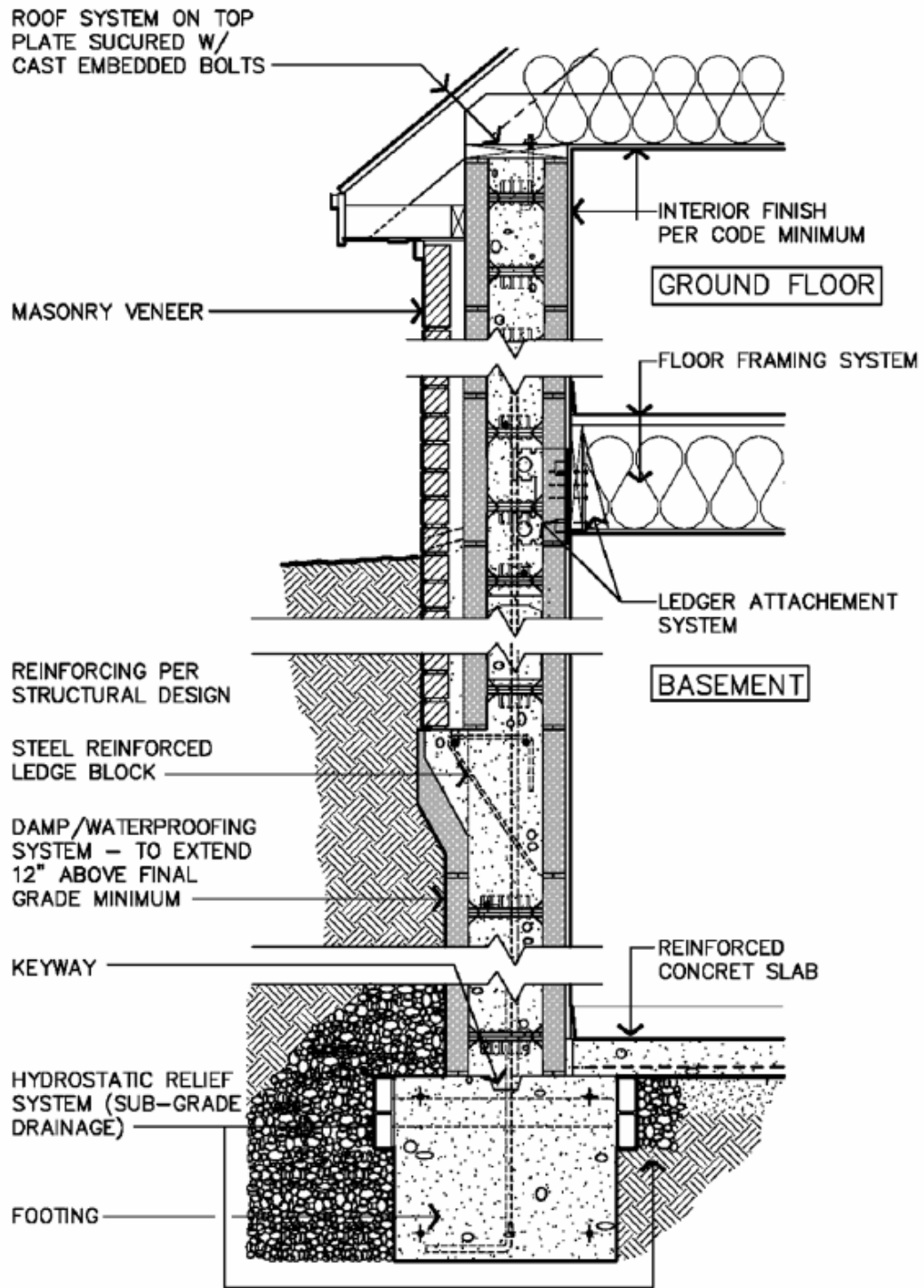

FIGURE 2 – BUILDBLOCK® AND BUILDLOCK® BASEMENT WALL DETAIL (TYPICAL)

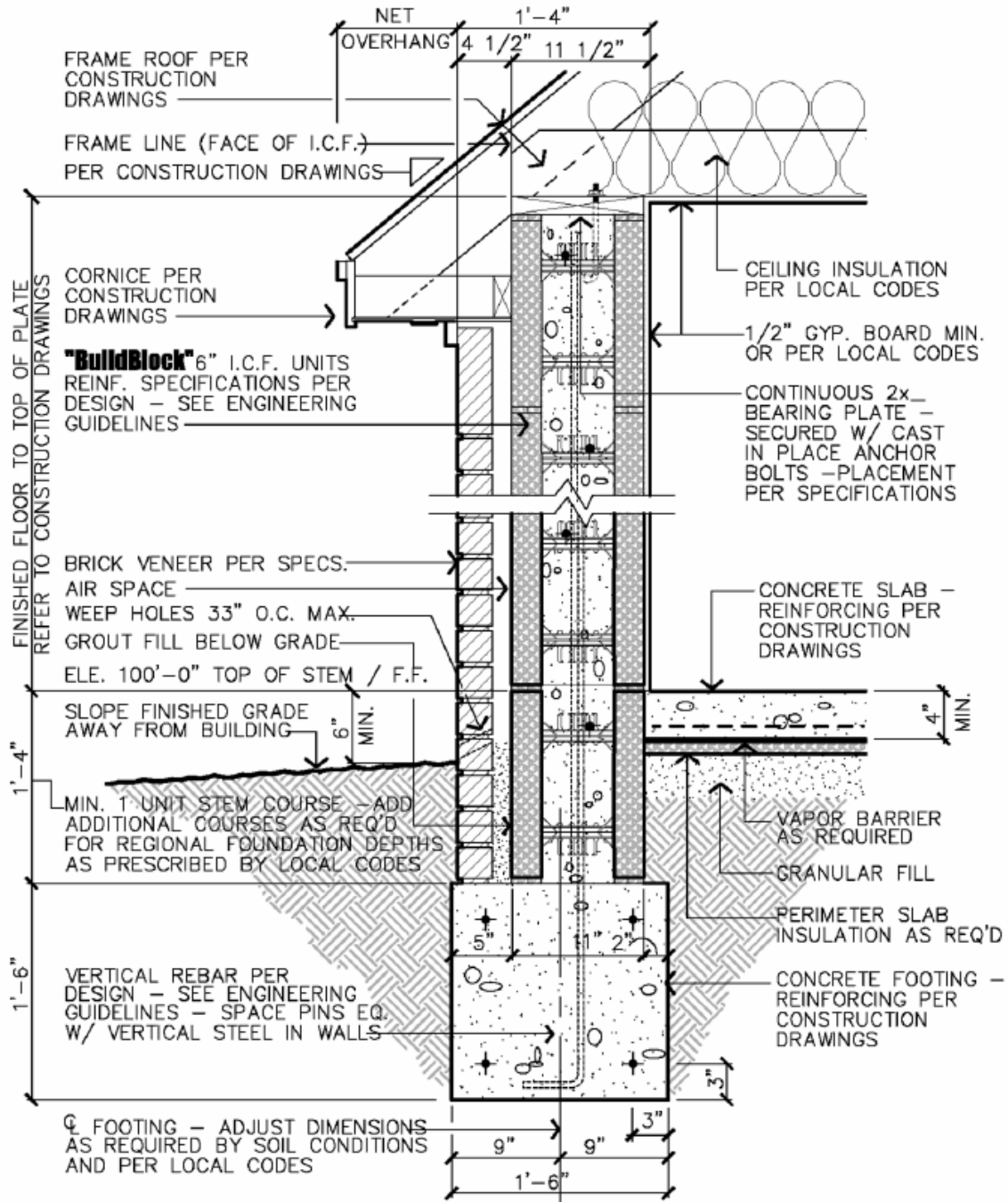

FIGURE 3 - BUILDBLOCK® AND BUILDLOCK® SINGLE STORY WALL DETAIL (TYPICAL)