

BUILDBLOCK BUILDING SYSTEMS
BUILDBUCK PRODUCT & INSTALLATION MANUAL
REVISED 2023

BUILDBUCK PRODUCT & INSTALLATION MANUAL

TABLE OF CONTENTS

BUILDBUCK ICF DOOR & WINDOW BUCKING	1
BuildBuck Specifications	1
<i>Overview</i>	1
<i>BuildBuck Design</i>	1
<i>BuildBuck Product Specifications</i>	2
<i>Standard Specification for Rigid, Cellular Polystyrene Thermal Insulation</i>	2
BuildBuck Benefits	3
<i>BuildBuck Features</i>	3
BuildBuck Product Design	4
BUILDBUCK INSTALLATION	6
BuildBuck Installation Methods	6
<i>BuildBuck Install Overview</i>	6
<i>BuildBuck Installation Method A</i>	6
<i>Cutting BuildBuck</i>	7
<i>Assembling BuildBuck</i>	8
<i>Buck Installation Method B:</i>	9
<i>General BuildBuck Installation Notes</i>	9
Window Installation	10
Door Installation	10
Flashing And Weatherproofing	10

BUILDBUCK PRODUCT & INSTALLATION MANUAL

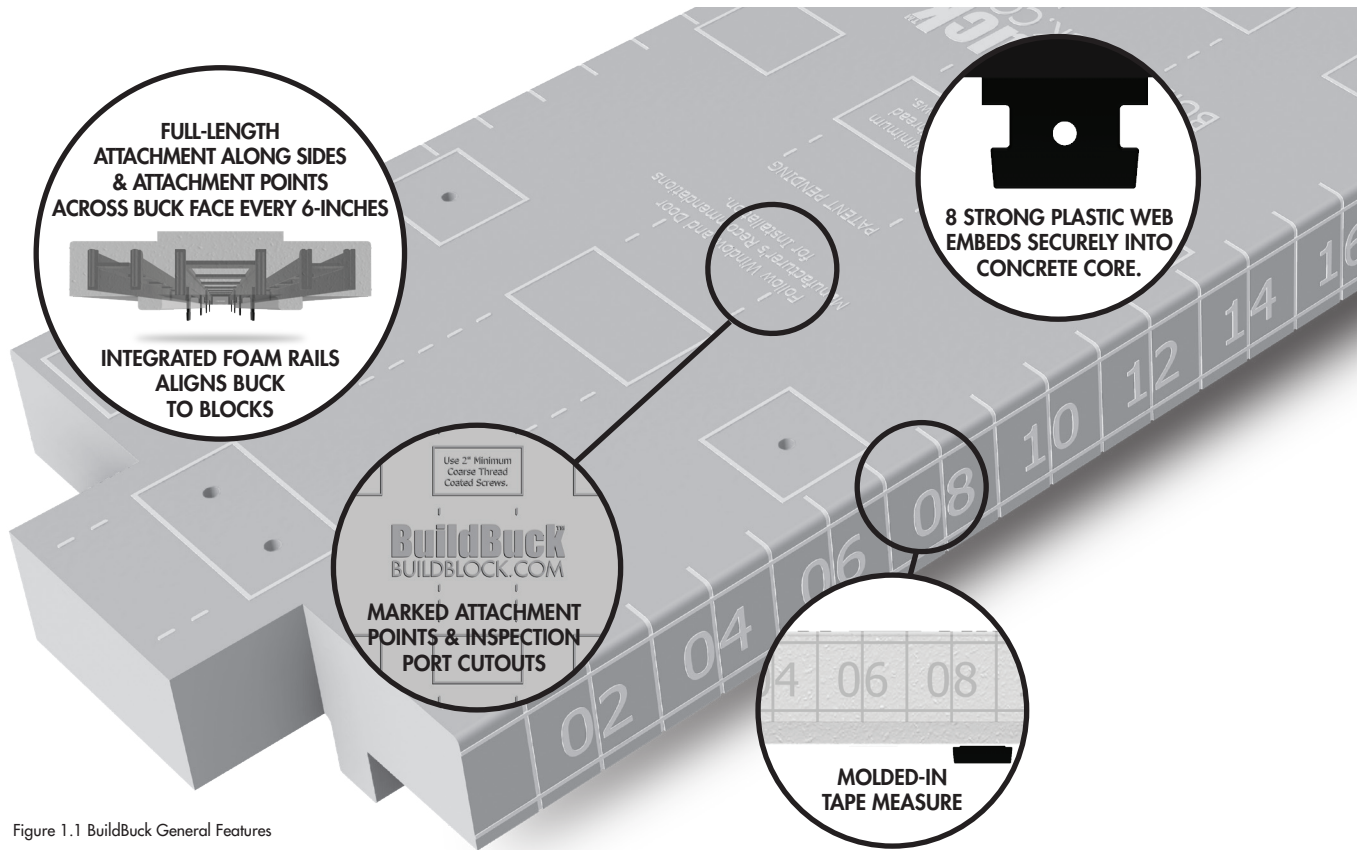

Figure 1.1 BuildBuck General Features

BUILDBUCK ICF DOOR & WINDOW BUCKING

BUILDBUCK SPECIFICATIONS

OVERVIEW

BuildBuck is a composite ICF bucking system made from Expanded Polystyrene (EPS) foam and Polystyrene plastic webs. The webs are fully embedded within a foam exterior. The buck is 52 inches long (48-inches nominal) and 2-inches thick. BuildBuck will create a 4 foot by 4 foot (inside dimensions) rough opening, with no cuts.

The Foam panel is Type IX 1.8pcf density EPS foam. Type IX EPS foam has an R-value of 4.35/inch. The panels are 2-inches thick yielding an R-value of 8.7. The average compressive strength of Type IX EPS is 25psi.

The full foam wrap serves to eliminate the condensation issue caused by thermally different materials below stucco or EIFS finishes. As seen in some older ICFs, stucco finishes can highlight the location of exposed plastic webs, as they warm up slower, and retain atmospheric moisture longer, leaving dark spots on the stucco over every web.

Each factory end of the EPS panel will interlock with the opposite factory end of another panel. These end details help to prevent air transfer at corners. When butting two non-factory ends, caulk or spray foam may be used to seal the joint. BuildBlock recommends cutting a factory edge into any cut pieces to ensure a full seal at all joints. Caulking should be placed around all windows to seal between the buck and the

window frame. Flashing should wrap around the buck edges and onto the ICF blocks to prevent possible leaks around the bucks.



Figure 1.2 BuildBuck Side Profile showing tape measure.

BUILDBUCK DESIGN

The EPS panel is further supported by 3 I-beams webs placed within the foam panel. These serve as both lateral reinforcement and attachment points for the windows. The I-Beams are made of strong Polystyrene plastic which also bonds to the EPS foam when molded, creating a composite reinforcement system. The two outer beams are used to attach new construction windows or flush mount replacement windows.

Full length attachment strips are marked and located on each edge of the buck and eight (8) attachment points are marked and located across the top of the bucks. There are seven (7) full size connectors on the top surface, and two (2) half-size connectors at each end.

The center support has 8 "T" locks which embed into the concrete anchoring the buck in place and providing rigid attachment for commercial or replacement style windows or for screwing finish materials to the buck's inside surface. These rigid connections provide the support needed for commercial applications and storm ready window systems.

BUILDBUCK PRODUCT & INSTALLATION MANUAL

BUILDBUCK PRODUCT SPECIFICATIONS

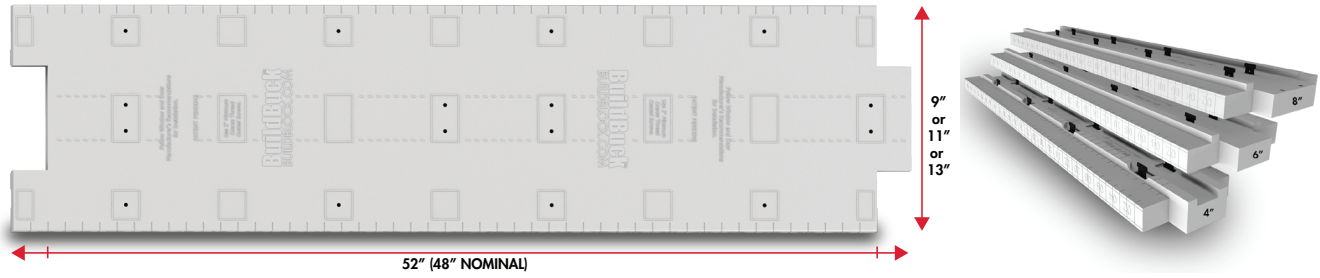

Figure 1.3 BuildBuck Product Physical and Nominal Dimensions.

BUILDBUCK SPECIFICATIONS								
PRODUCT	LENGTH	NOMINAL LENGTH	WIDTH	THICKNESS	WEIGHT	R-VALUE	AREA	FORMS
BK-600 BuildBuck 11 in	52 in 1320.8 mm	48 in 1219.2 mm	11 in 228.6 mm	2 in 50.8 mm	4 lbs. 1.81 kg	8.4	3.82 ft ² .3550 m ²	BB-600 BL-600 GB-600
BK-800 BuildBuck 13 in	52 in 1320.8 mm	48 in 1219.2 mm	13 in 279.4 mm	2 in 50.8 mm	4.5 lbs. 2.04 kg	8.4	4.51 ft ² .4190 m ²	BB-800 BL-800 GB-800

NOTE: BuildBuck is compatible with all 6" & 8" ICF blocks with 2.5" thick EPS foam panels.

STANDARD SPECIFICATION FOR RIGID, CELLULAR POLYSTYRENE THERMAL INSULATION

Specification Reference: ASTM C 578-92			Type I	Type VIII	Type II	Type IX
Property	Units	ASTM Test				
Density, minimum	(pcf)	D 303 or D 1622	0.90	1.15	1.35	1.80
Density Ranges	(pcf)	C 177 or C 518	0.90-1.14	1.15-1.34	1.35-1.79	1.80-2.20
Thermal Conductivity K Factor	at 25 F	BTU/(hr.)	0.23	.22	.21	.20
	at 40 F	(sq.ft.)(F/in.)	0.24	.235	.22	.21
	at 75 F		0.26	.255	.24	.23
Thermal Resistance R-value	at 25 F	at 1 inch	4.35	4.54	4.76	5.00
	at 40 F	thickness	4.17	4.25	4.55	4.76
	at 75 F		3.85	3.92	4.17	4.35
Strength Properties						
Compressive 10% Deformation	psi	D 1621	10-14	13-18	15-21	25-33
Flexural	psi	C 203	25-30	30-38	40-50	50-75
Tensile	psi	D 1623	16-20	17-21	18-22	23-27
Shear	psi	D 723	18-22	23-25	26-38	33-27
Shear Modulus	psi	—	280-320	370-410	460-500	600-640
Modulus of Elasticity	psi	—	180-220	250-310	320-360	460-500
Moisture Resistance						
WVT	perm. in		2.0-5.0	1.5-3.5	1.0-3.5	0.6-2.0
Absorption (vol.)	%		less than 4.0	less than 3.0	less than 3.0	less than 3.0
Capillarity	—		none	none	none	none
Coefficient of Thermal Expansion	in./(in.)(F)	D 696	0.000035	0.000035	0.000035	0.000035
Maximum Service Temperature						
Long-term Exposure			167	167	167	167
Intermittent Exposure			180	180	180	180
Oxygen Index	%	D 2863	24.0	24.0	24.0	24.0

BUILDBUCK PRODUCT & INSTALLATION MANUAL

BUILDBUCK BENEFITS

BuildBuck uses the same materials found in BuildBlock ICFs to ensure your wall maintains consistent insulation around door and window openings. BuildBuck doesn't swell, cup, or react to the water in the concrete creating a smooth square opening for installation of windows and doors. BuildBuck ICF Door & Window Bucking brings the insulation properties of EPS foam together with embedded plastic webs to create a strong seamless transition from ICF walls to door and window openings.

BUILDBUCK FEATURES

- Strong I-Beam web design mechanically anchored into concrete and foam.
- Standard BuildBlock labor-saving benefits are included such as molded-in tape measure and cut lines.
- Indicators for attachment points and cut lines for access ports are molded-in.
- Full-length attachment points along each side of the buck for easy attachment of finishes.
- 8 attachment zones across the face of the buck spaced evenly every 6-inches.
- BuildBuck has 8 anchors that mechanically secure the buck to the concrete wall.
- BuildBuck is 2" thick and 52" long (48" nominal) and the longest ICF buck on the market creating a 4040 rough opening without cutting.
- Packaged in small bundles for easy ordering and fits above block bundles on trucks to eliminate most shipping costs.
- Webs are molded 1/2 inch below the EPS foam to prevent thermal bridging and create a seamless transition from wall to opening.
- BuildBuck is available for all 4, 6, & 8-inch forms.

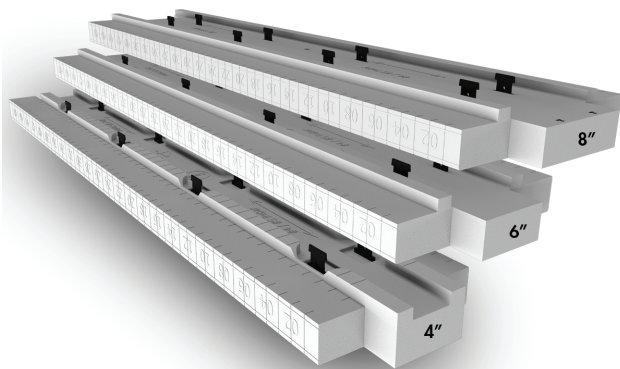

Figure 1.4 BuildBlock basement and first floor showing cutaway of BuildBuck integrated into wall with cross bracing.

BUILDBUCK PRODUCT & INSTALLATION MANUAL

BUILDBUCK PRODUCT DESIGN

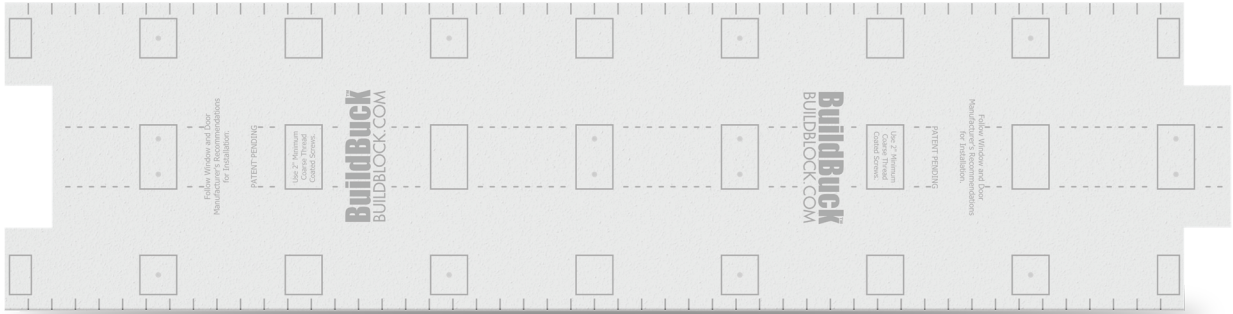

Figure 1.4 BuildBuck top face with attachment points, cut lines, and inspection port markings.

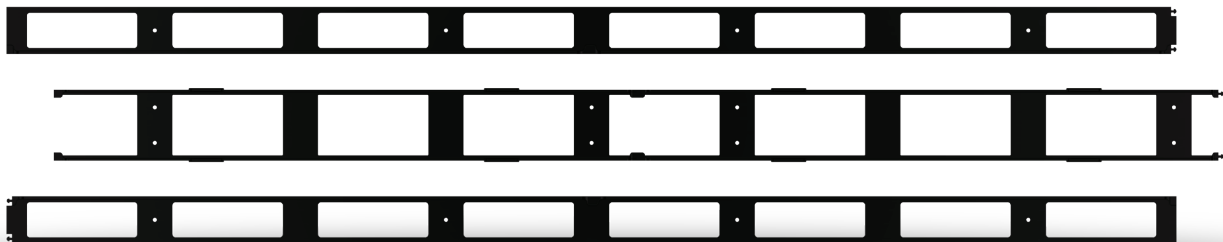

Figure 1.5 BuildBuck embedded webs top view.



Figure 1.6 BuildBuck side view with molded-in tape measure and cut lines.



Figure 1.7 BuildBuck webs side view showing "T" locks that embed into the concrete securing the buck to wall.



Figure 1.8 BuildBuck end view showing factory connection



Figure 1.9 BuildBuck end view showing factory connection and plastic "T" anchors that embed into the concrete securing the buck to the wall.

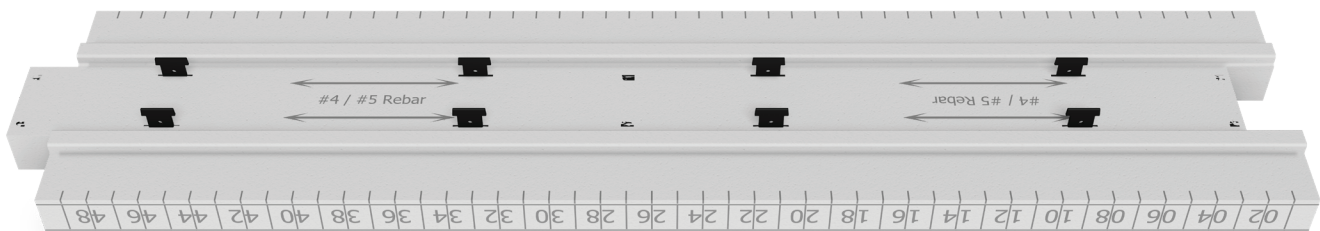

Figure 1.10 BuildBuck bottom showing cut lines, alignment rails, and "T" anchors for concrete attachment.

BUILDBUCK PRODUCT & INSTALLATION MANUAL



Figure 1.11 BuildBuck Buck showing end connection and "T" concrete anchors.

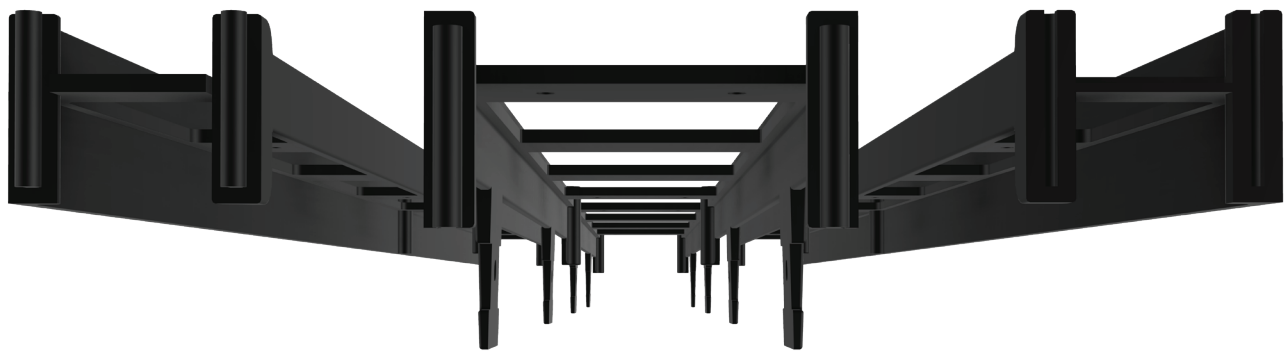

Figure 1.12 Embedded BuildBuck webs for attachment points and "T" concrete anchors.

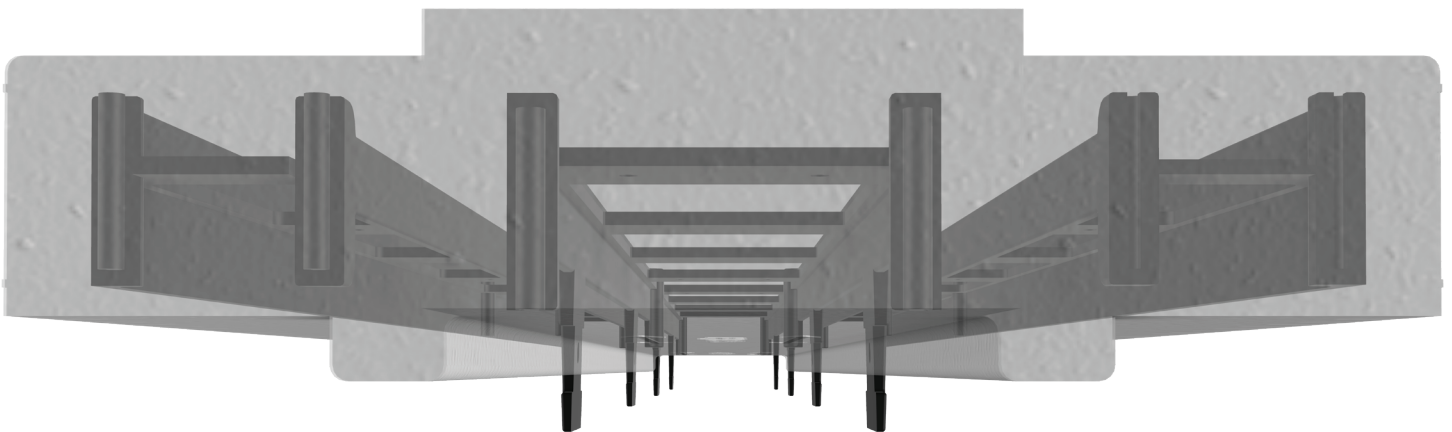

Figure 1.13 BuildBuck assembly showing embedded webs with "T" concrete anchors and foam insulation.

BUILDBUCK PRODUCT & INSTALLATION MANUAL



Figure 2.1 BuildBuck poured and bracing remove after concrete fully cured.

BUILDBUCK INSTALLATION

BUILDBUCK INSTALLATION METHODS

BUILDBUCK INSTALL OVERVIEW

1. BuildBuck may be installed using one of two common methods:
 - A. This first method is to cut and install buck pieces into the ICF wall as the ICF walls are being built. The buck panels are very light and this is a very easy method for a single person.
 - B. Method two is to build all bucks prior to stacking any ICF blocks and install as single units as the walls are being stacked. This is often done as other portions of a crew is preparing the site, snapping lines, and preparing for block installation.

BUILDBUCK INSTALLATION METHOD A

1. Use the window rough opening dimensions provided by the window or door manufacturer. (The extra width and height of actual window or door size is for plumbing the window or door with shims on final installation.)
 - A. This size is the finished rough opening inside of the window or door buck.

2. Increase rough opening dimensions to compensate for the 2-inch thickness of BuildBuck for windows and doors.
 - A. For all windows, add 4 inches to the width and height. This is to account for the thickness of the buck material.
 - B. For all door openings, add 4 inches to the width and 2 inches to the height to account for the thickness of the bucking material. Door openings do not require a buck sill making the difference in height 2 inches.
 - C. These dimensions are the outside size of the buck, and the size of the opening hole in the ICF wall before the buck is placed inside.
3. Mark all window and door centers and the overall width of the openings and heights of the finished out-to-out buck dimensions on the slab next to each opening. This will save time for checking each door or window opening during assembly and final checks on all openings prior to the concrete pour.
4. For window openings stack ICF walls to the window sill height plus 2-3 courses on both sides of window openings. Make sure opening sides are plumb and the same width top to bottom.

BUILDBUCK PRODUCT & INSTALLATION MANUAL

- A. Ensure the running bond is created by offsetting ICF blocks as they are stacked. If a common seam is placed at the opening, ensure blocks are held in place securely and remain plumb. Always verify widths above and below openings to make sure they are consistent and do not grow or shrink.
 - B. You may want remove the BuildBlock interlock connection before setting the buck sill in place. This ensures a better buck seal and may eliminate any compression of the interlock under the vertical bracing during the pour.
 - C. Attach the buck to adjacent blocks with adhesive foam for a complete seal.
 - D. If you need the extra sill height from the height of the interlock, foam in the block fingers thoroughly to seal the connection securely before setting the buck sill in place. This is important to prevent any moisture from intruding between the buck and the block into the wall cavity.
5. For door openings stack ICF walls 2-3 courses high on both sides of door openings as marked on the slab.
 - A. Make sure opening sides are plumb square and of the same width top to bottom. This is very important otherwise your opening will not be plumb and square.
 - B. Always verify widths above and below openings to make sure they are consistent and do not grow or shrink.
4. Cut the top buck panel(s) to length. If using factory connections cut correct connection into the ends as needed. Otherwise place top panel(s) directly on top of the window buck side panel(s).
 5. Installing the buck sides with the male end up will provide the most bearing for the top buck when using factory connections during the installation. This is only a suggestion. Otherwise refer to item 3 above.
 6. On a 4 foot by 4 foot inside to inside rough opening, all 4 corners will be factory corners.
 7. For larger windows and doors connecting the buck pieces together allows the length to be measured prior to cutting. This may help resolve cutting errors.

CUTTING BUILDBUCK

1. For the sill bottom, measure the BuildBuck panels, starting from a factory end, and cut to the full width of the rough opening. This includes the 4 inches of the buck material thickness on each side as described previously. This width should match the measurements of the opening written on the slab and the opening cut into the ICF wall.
 - A. No bottom buck piece is typically required for door openings. If the opening is wider than the full length of a buck panel, subtract 50 inches from the total opening dimension, and cut an additional piece to create the proper length desired for the opening.
 - i. Leave the factory edge on the cut piece so that it fits the end of the first side panel. You can leave the cut end as is or cut it to a factory male or female end as needed.
 - ii. BuildBlock recommends that a factory end be cut on the ends as this seals the buck joint much better than a butt connection when properly glued together with foam.
2. On windows set the sill bottom buck into the opening checking dimensions of opening to match the buck length exactly as desired.
3. BuildBuck Sides



BUILDBUCK PRODUCT & INSTALLATION MANUAL

Figure 2.2 BuildBuck cross bracing in place with lateral and longitudinal bracing across the bottom. This equally distributes vertical pressure across embedded webs and provides concrete window inspection port access for concrete consolidation and vibrating.

ASSEMBLING BUILDBUCK

1. The bucks may be glued in place with adhesive foam if desired.



Figure 2.3 Concrete window inspection ports fully filled.

2. On window bucks before gluing the sill panels in place in the wall opening we suggest that concrete window inspection ports be cut every 12 inches between the support beams in the bottom buck sill. These areas are marked on BuildBuck Panels.
 - A. This ensures full concrete consolidation when vibrating and filling concrete below the window and under the buck sill during the pour. Make these cut outs prior to setting the sills in the wall to prevent waste and foam beads entering the ICF wall cavity. Use the dotted lines marked on the buck as a reference.
 - B. BuildBlock strongly cautions against cutting through the longitudinal webs in the buck, as this can reduce the strength of the buck significantly. Hole saws with a maximum diameter of 2-1/2 inches will work as well.
3. After cutting the concrete window inspection ports in the sill panel(s) glue the sill buck panel(s) in place.
4. Glue connections on both sill buck ends with foam adhesive. If desired run a bead of glue along the end of the ICF blocks in the wall that connect to the buck. Set side buck pieces in place on each side of the opening. Secure in place with appropriate tape to hold firmly until the foam adhesive sets.
5. As side buck pieces are installed plastic tees may be tied to the BuildBlock webs using the holes in the center of the tees with tie wire. This may eliminate the need of the tape to hold buck sides in place. Measure opening width to ensure proper dimensions; adjust and shim if necessary.
6. Continue stacking the wall one course at a time and cut blocks to fit against the side buck panels on each opening. Be careful to keep the sides of the blocks and the buck opening plumb. Check buck width dimensions often to ensure you are not pushing the blocks against the bucks and moving them inward.
7. When stacking blocks, glue the top of the opening buck panel(s) in place as you reach the top of the opening. If the window is wider than one buck panel glue ends of the buck together before installing, or place bracing in place to support the top buck panel(s).
8. Recheck all buck dimensions for accuracy in both directions. Plumb and square on all corners.
9. After installing all buck panels the window or door opening will need bracing as outlined in the diagram below.
 - A. 2X material is recommended for all bracing.
 - i. After installing bracing materials make sure the proper screws are placed as shown in the diagrams. It is very important to hold all items securely during the concrete pour. There are enormous concrete pressures on the buck in the openings and it is very important that bracing be placed carefully and thoroughly. Otherwise concrete will move the buck sides or top into the opening area and the window or door will not fit as planned.
 - ii. Concrete is very unforgiving and though a foam buck may be rasped for minor adjustments during final fitting of your windows and doors, do not take any undo chances by not using proper bracing procedures. Please install as shown.
10. Finish stacking blocks around the buck and foam glue blocks to the bucks as desired.
11. One last time, before pouring your walls check that all openings are plumb with square corners and that dimensions in both height and width match your window or door rough openings.

BUILDBUCK PRODUCT & INSTALLATION MANUAL



Figure 2.4 Corner bracing properly attached to lateral and longitudinal braces. Side braces attached to buck face.



Figure 2.5 Fully cross braced 4040 rough opening.

BUCK INSTALLATION METHOD B:

1. This method builds the bucks prior to stacking the walls. Please follow all the directions as noted in the above Method A. for sizing, measurements, wall stacking etc.
2. The only difference between the two methods is building the bracing frames first and then cutting buck panels and attaching them with screws around the bracing frame. All the measurements and cutting will be exactly the same but in reverse. Also the buck will be inserted at one time as a complete unit and not inserted panel by panel.

3. Cut dimensional lumber braces and assemble as noted in the diagrams. Note the bracing outside dimensions will match your rough opening size for your windows and doors. Screw braces together and square them using cross bracing before cutting the bucks, assembling, and attaching them to the bracing. Cross bracing will be required with this method otherwise the bucks will not be square.
4. Cut and attach all bucks to the bracing frames by screwing into the buck faces. This holds the buck panels securely to the bracing frames.
5. Stack blocks as directed in Method A., but be careful not to stack the wall sides too tall. This is usually 2 blocks maximum because the completed buck assembly must be lifted over the top of the opening and lowered in position.
 - A. Verify all dimensions before setting bucks and bracing in place as a whole unit. This usually requires two people to lift and set them into place versus the other method that one person can accomplish themselves.
6. Foam around the bucks to secure them to the blocks completely. Tape may also be used around the sides of the opening to secure the bucks to the blocks.
7. Follow all other installations instructions below.



Figure 2.6 Bracing using 2x6 vertical bucking and 2x4 cross bracing turned laterally.

GENERAL BUILDBUCK INSTALLATION NOTES

1. The frame should be squared and cross braced. Optionally, corners can be braced with Plywood triangles to further ensure a square opening.
2. Window bucks should have all 4 sides braced. Door bucks should have a bottom brace to ensure the base of the door buck does not press inward during the pour reducing the opening width.
3. Horizontal and vertical braces should be continuous lumber. Cross bracing should lay on edge and cross each other at the center of the opening.
 - A. 2X lumber is typically used for this application. BuildBlock recommends 2x6 for the top, sides, and the lateral braces on the bottom. 2x4's may be used for cross bracing and the longitudinal braces on the bottom.

BUILDBUCK PRODUCT & INSTALLATION MANUAL

- B. Vertical and horizontal cross bracing should be placed every 18" to 24".
4. Add triangle braces on opposing corners to ensure buck remains square during the pour.
 5. Join each buck piece using the factory connections or butt them together to buck full opening. If connecting multiple pieces of buck use factory ends, create a new factory end connection by cutting the buck, or connect end to end without the interconnection. A small amount of foam adhesive may be used to join buck pieces.
 6. Concrete window inspection ports should be cut between the support beams in the bottom buck every 12 inches to ensure full consolidation below the window. Doing this before buck installation prevents debris from falling into the wall cavity. Follow the dotted lines marked on the buck as a reference. BuildBlock strongly cautions against cutting through the longitudinal webs in the buck, as this can reduce the strength of the buck significantly. Alternately a small hole-saw may be used to cut inspection holes in the sill (2-1/2" MAX).
 7. Remove Interlock fingers from top of blocks below openings and from bottom of blocks above the openings. Buck should not rest on interlock, as some compression may occur.
 8. Attachment points on the face of the buck and sides can be used to attach bracing and strapping.
 9. Fill any voids or gaps with spray foam to prevent concrete spillage. Take care with spray foam. You only want to seal any gaps. Too much spray foam can flex the buck, or expand into the concrete core, and prevent proper concrete cover at the rebar.
 10. Strapping across openings tying buck and blocks together to prevent lateral movement is required across large openings and when close to corners or wall terminations.
 11. Nylon strapping tape (1" or wider) may also be used to retain the bucks against the ICF. The foam must be clean and free of dust for proper adhesion of the tape.
 12. Ensure that steel rebar is placed completely around the buck opening as per engineering and prescriptive methods. Don't forget to add the rebar under the window openings before installing the buck materials. Side steel rebar must be located within 6" of the opening sides and tied if necessary to maintain that position. All lintels above openings must meet engineering requirements along with proper stirrups for the application. Refer to rebar engineering tables in the BuildBlock installation manuals.
 13. Vertical door and window bracing should remain in place 7-14 days after pouring to ensure concrete curing. If loading headers during framing it is recommended to leave vertical bracing in place. Concrete typically cures completely in 28 days at standard temperatures. If cooler weather is present this time will be extended and if hotter it may be shorter.

WINDOW INSTALLATION

1. Determine the type of window to be installed.
2. For a new construction window with a flange, the side connections will be used.
3. These are located 1/2" below the foam on the sides of the buck.
4. The window should be attached with a 1-1/4" fully threaded screws. For certain applications, a longer screw may be used to reach the center beam and attach to the plastic web beam that is also attached to the concrete. (4-1/2" for the 6" concrete core 11" buck and 5-1/2" for the 8" concrete core 13" buck).
5. Ensure that the screws attach inside outlined boxes on the sides of the panels.
6. For replacement or commercial windows without a flange, the windows must be placed carefully to ensure that adequate attachment is aligned properly with the window's attachment strips.
7. The boxes outlined on the face of the buck indicate where the attachment points are located.
8. The center points are embedded into the concrete via the "T's" on the center beam's back surfaces.

DOOR INSTALLATION

1. Door jambs should be installed plumb and square against the buck. For standard door attachments. The center beam should be used for attaching the jambs, with additional fasteners if necessary attaching to the side beams.
2. Mark the location of the attachment points onto the side of the buck, to ensure a solid connection. Some applications may require a direct connection to the concrete.
3. This is easily accomplished, through the foam, with either a Tapcon or RedHead screw, or using concrete anchors.
4. Optionally, on heavy commercial projects, a reinforced attachment point can be achieved by cutting out the concrete window inspection ports in the buck on the sides and top. Covering them with either bracing or additional lumber.
5. Allow the concrete to flow to the face of the buck.
6. Tapcons or red-heads may be used to fasten the jambs into the concrete with this method.

FLASHING AND WEATHERPROOFING

1. Flashing around openings ensures a weatherproof seal. The goals of weatherproofing and flashing are:
2. Prevent water from entering the home at openings and causing damage to interior trim, drywall, flooring, etc.
3. Ensure no drafts or cold or hot spots maximizing the efficiency of the ICF wall.

BUILDBUCK PRODUCT & INSTALLATION MANUAL

4. Flashing materials are varied. BuildBlock recommends a rubberized bitumen material such as Pollywall Window and Door Flash, or Aluminum HVAC tape to control air and moisture at the openings. **Use only water based or Emulsion type materials and adhesives for flashing. Petroleum based adhesives or solvents will dissolve the EPS foam.
5. Flashing should be applied from the bottom up. Flashing across the header should be last piece installed. This creates a natural watershed.
6. NOTE: Top of wall flashing is also important. Faulty flashing can allow moisture to drain inside ICF between the EPS foam and structural concrete core and will mimic a window or door leak.
7. Caulking should be applied around all window and door jambs to fill any gaps left by shimming. Larger gaps should use backer rod to fill behind the caulking. Caulking should be ICF safe, NP-1, acrylic, silicone, or other water based or emulsion material with high stretch and UV protection.

BUILDBUCK PRODUCT & INSTALLATION MANUAL

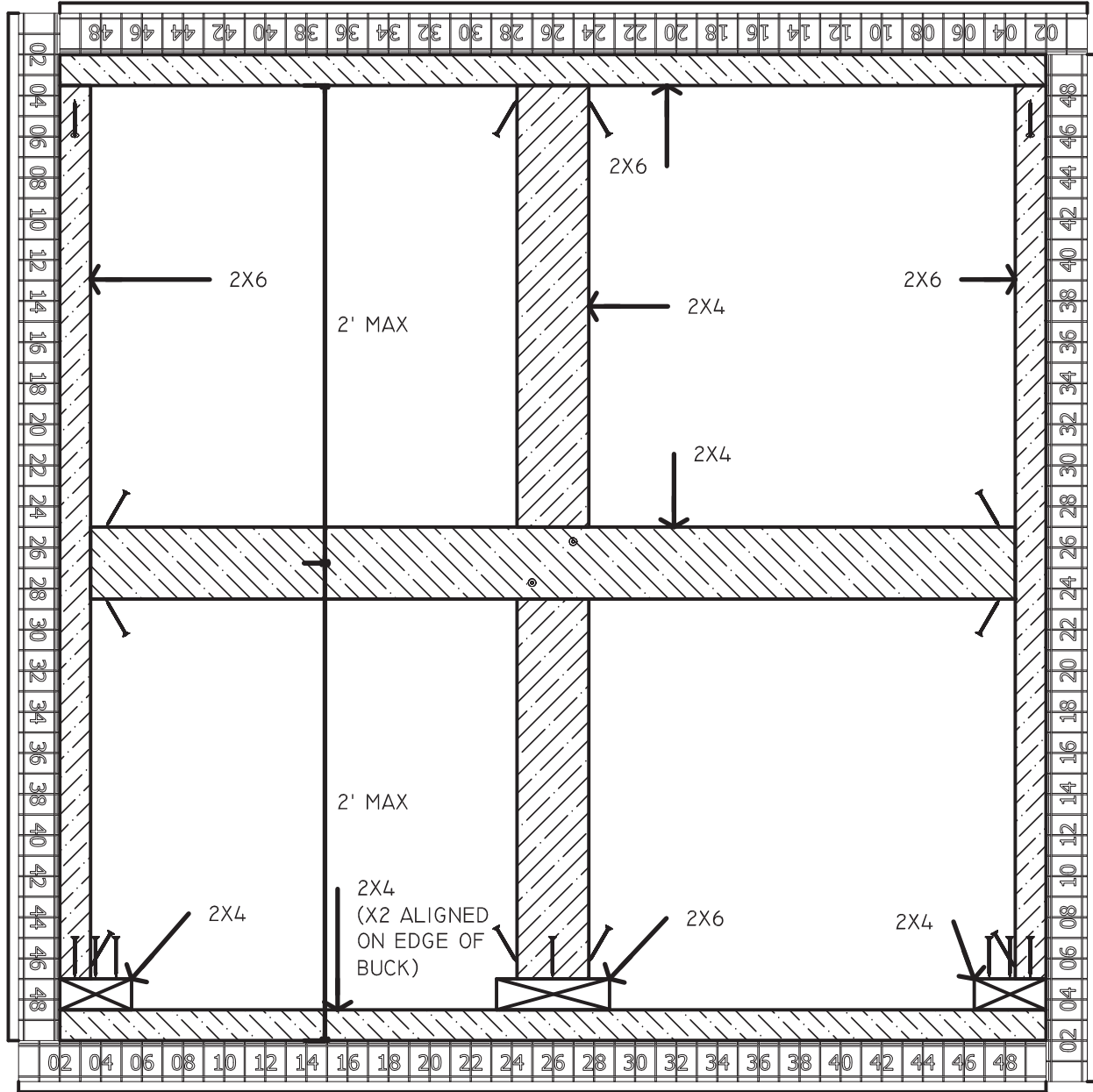

SCREW BRACING INTO THE FACE OF THE BUCK AT THE CONNECTION POINTS, NOT GREATER THAN 24" O.C.
 CROSS BRACES SHOULD BE SPACED A MAXIMUM OF 24" O.C.
 USE COARSE THREAD DECK SCREWS TO JOIN ALL BUCK BRACING.

Figure 2.7 Cross bracing design for BuildBuck Window Rough Openings.

BUILDBUCK PRODUCT & INSTALLATION MANUAL

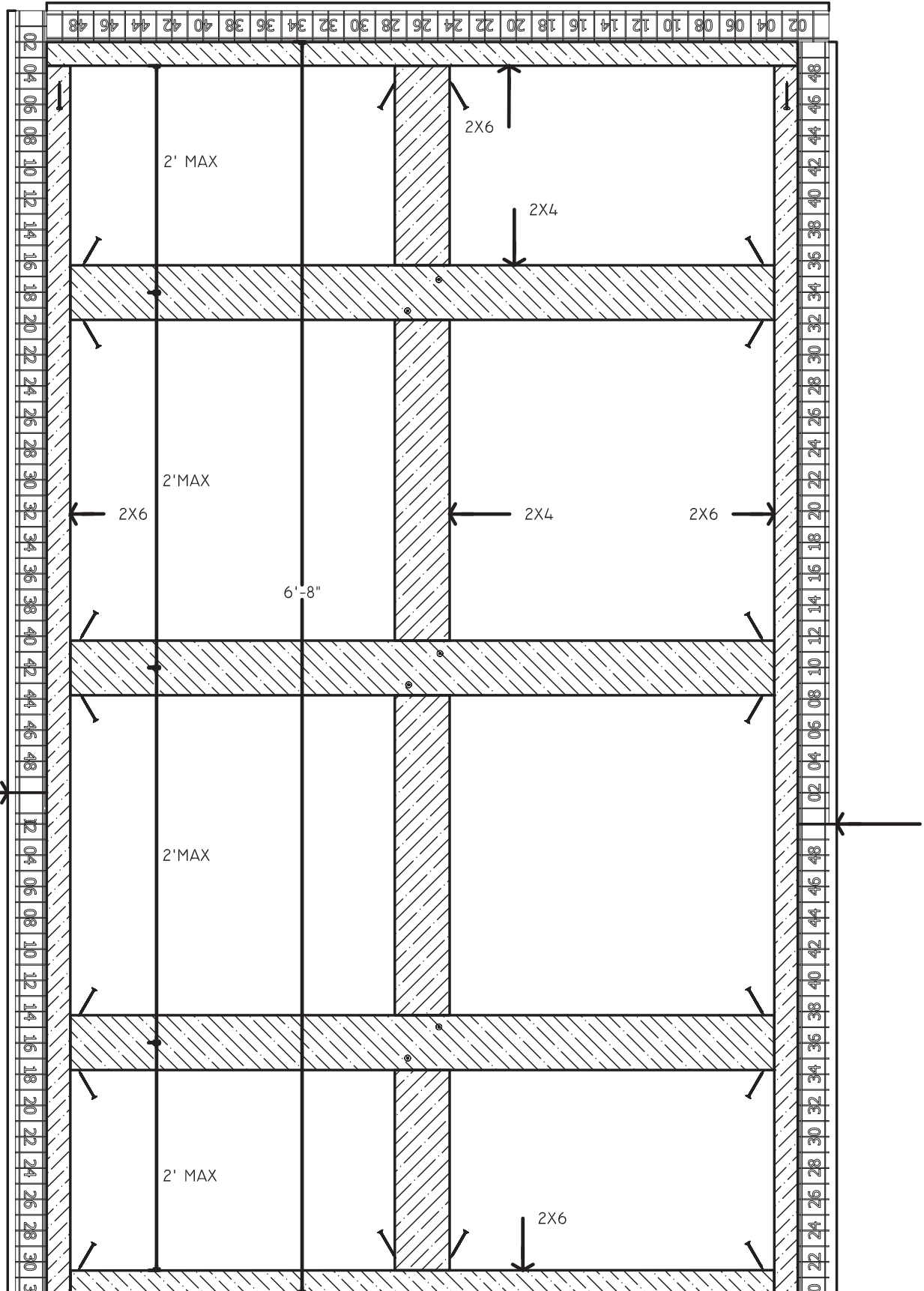
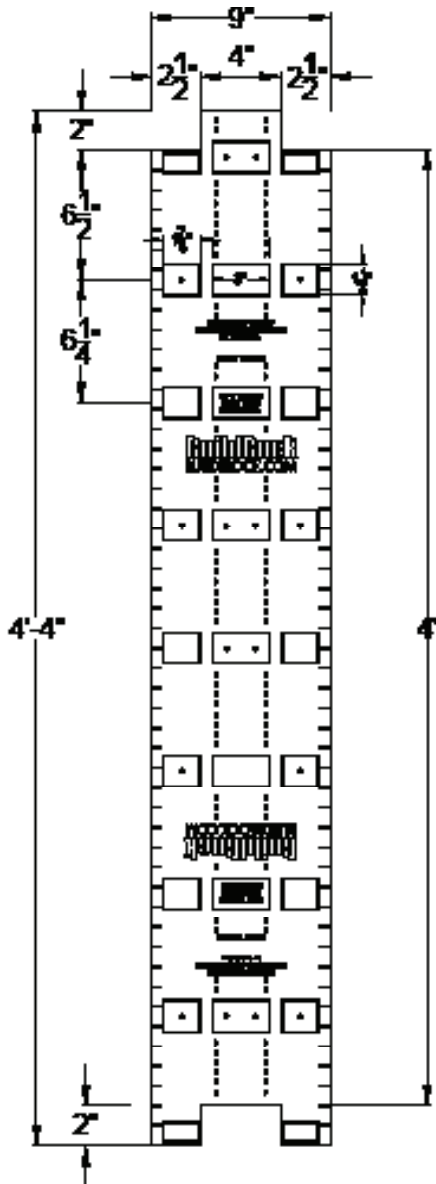
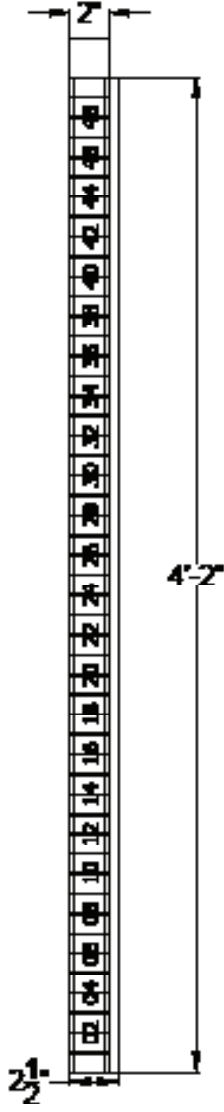

Figure 2.8 Cross bracing design for BuildBuck Door Rough Openings.



(1) TOP VIEW



(2) SIDE VIEW

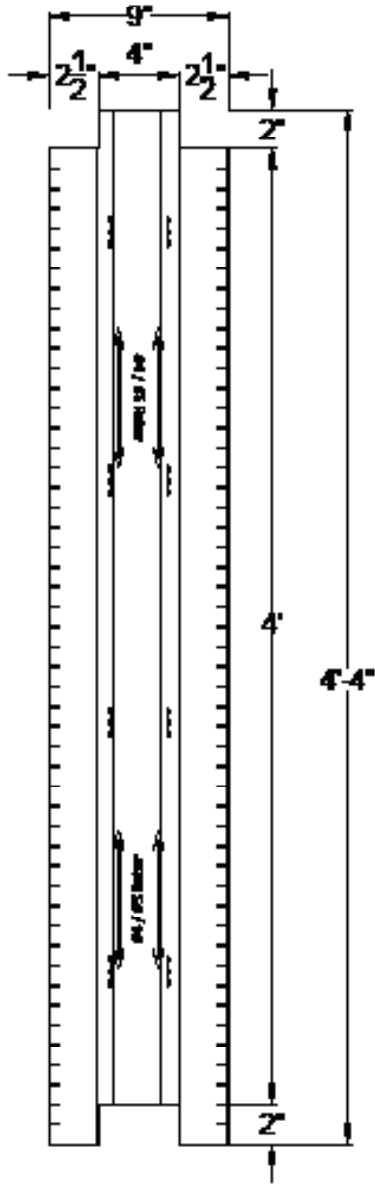

(3) BOTTOM VIEW

BK-400



BUILDBUCK 4" PRODUCT DIMENSIONS

DATE/REV	06/2023	SCALE	NTS	DETAIL SHEET
----------	---------	-------	-----	--------------

NOTES	
-------	--

9705 N. BROADWAY EXTENSION, SUITE 200, OKLAHOMA CITY, OK 73114
 OFFICE: 405-840-3386 | TOLL FREE: 866-222-2575 | FAX: 831-597-0792
 BUILDBLOCK.COM

CONSTRUCTION SHALL BE IN ACCORDANCE WITH ALL APPLICABLE LOCAL AND NATIONAL CODES. ALL DRAWINGS ARE SUBJECT TO CHANGE WITHOUT NOTICE.

62A

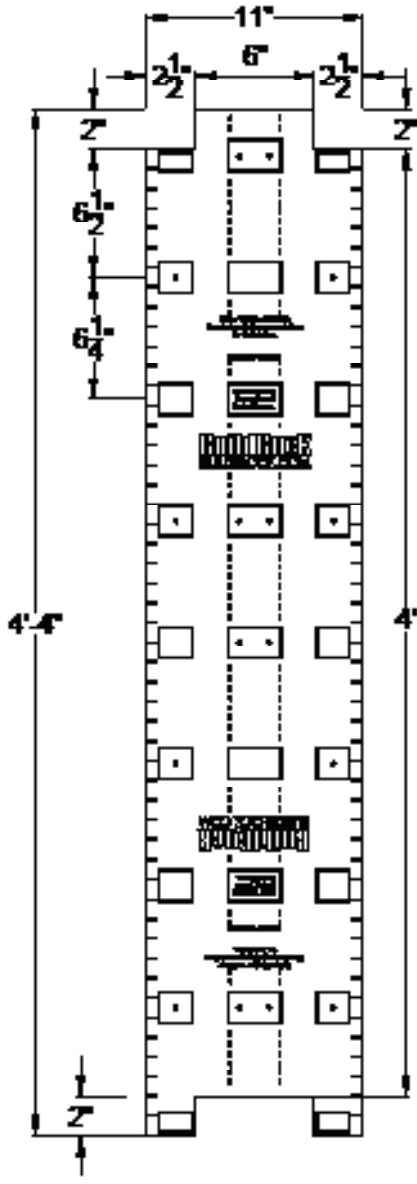

1 TOP VIEW

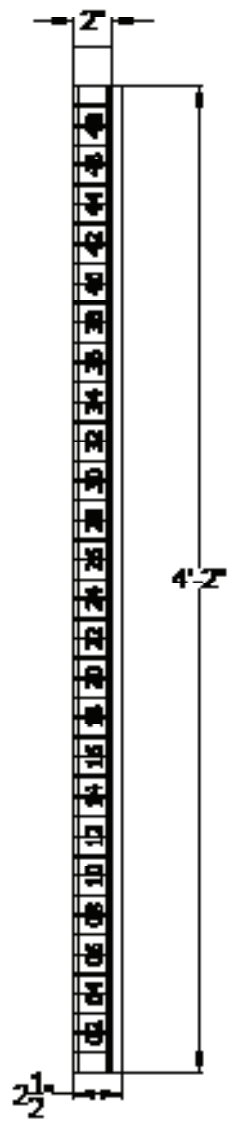

2 SIDE VIEW

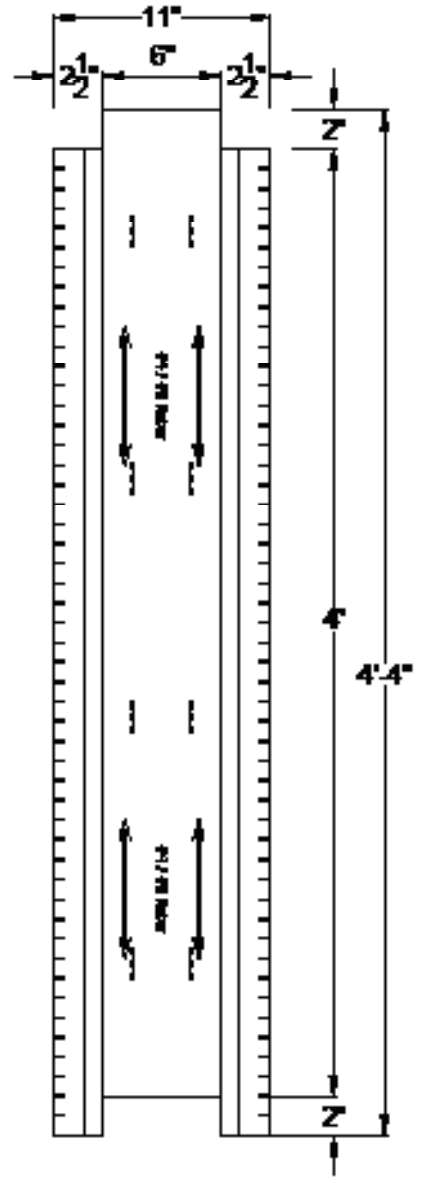

3 BOTTOM VIEW

BK-600



9705 N. BROADWAY EXTENSION, SUITE 200, OKLAHOMA CITY, OK 73114
 OFFICE: 405-840-3386 | TOLL FREE: 866-222-2575 | FAX: 831-597-0792
 BUILDBLOCK.COM

BUILDBUCK 6" PRODUCT DIMENSIONS

DATE/REV	06/2023	SCALE	NTS	DETAIL SHEET
----------	---------	-------	-----	--------------

NOTES

CONSTRUCTION SHALL BE IN ACCORDANCE WITH ALL APPLICABLE LOCAL AND NATIONAL CODES. ALL DRAWINGS ARE SUBJECT TO CHANGE WITHOUT NOTICE.

62A

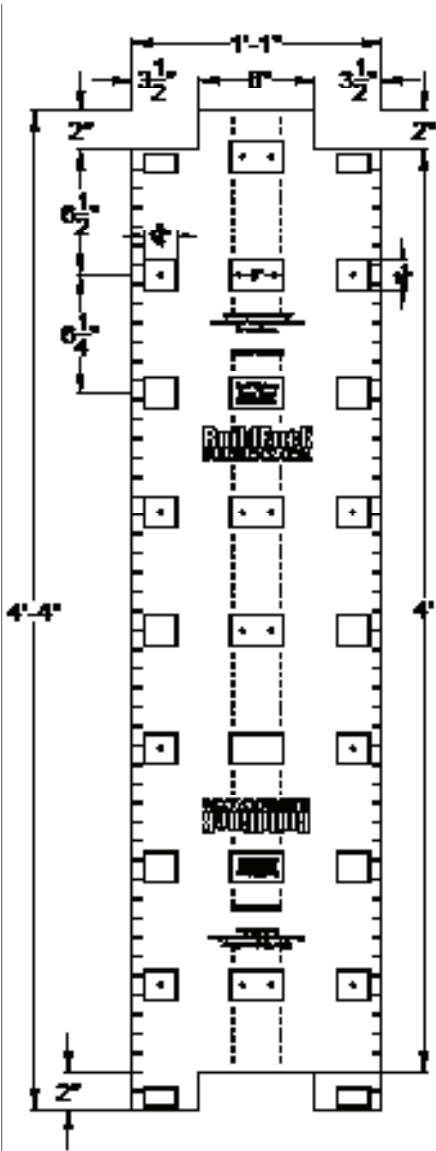

1 TOP VIEW

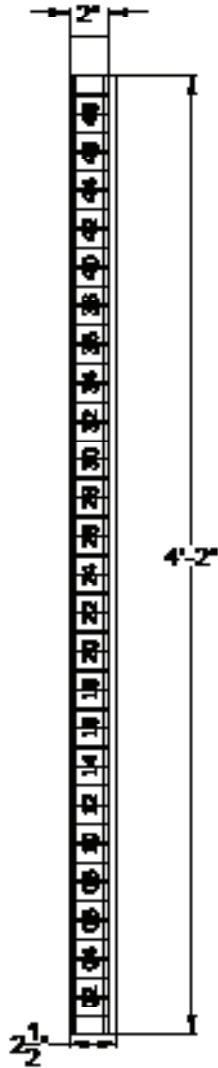

2 SIDE VIEW

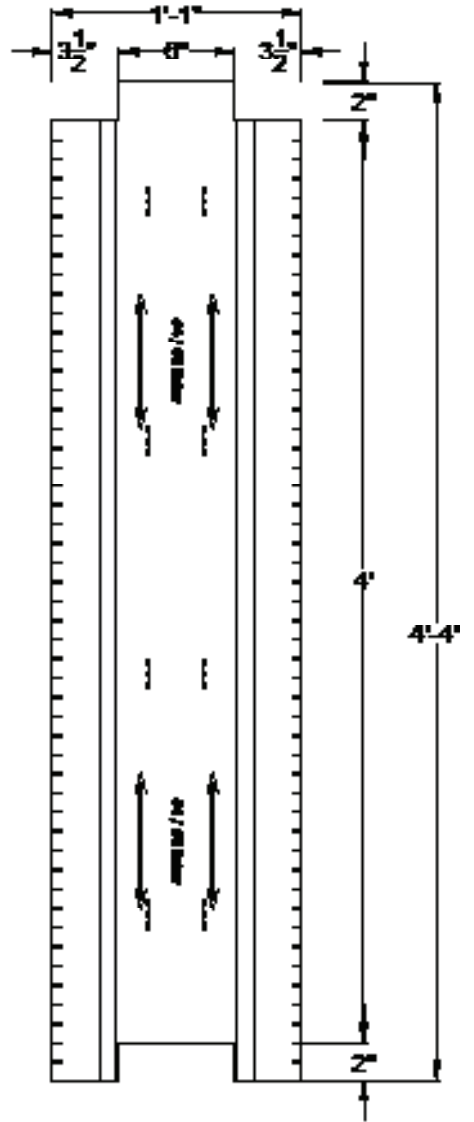

3 BOTTOM VIEW

BK-800



9705 N. BROADWAY EXTENSION, SUITE 200, OKLAHOMA CITY, OK 73114
 OFFICE: 405-840-3386 | TOLL FREE: 866-222-2575 | FAX: 831-597-0792
 BUILDBLOCK.COM

BUILDBUCK 8" PRODUCT DIMENSIONS

DATE/REV	06/2023	SCALE	NTS	DETAIL SHEET
NOTES				62B
CONSTRUCTION SHALL BE IN ACCORDANCE WITH ALL APPLICABLE LOCAL AND NATIONAL CODES. ALL DRAWINGS ARE SUBJECT TO CHANGE WITHOUT NOTICE.				

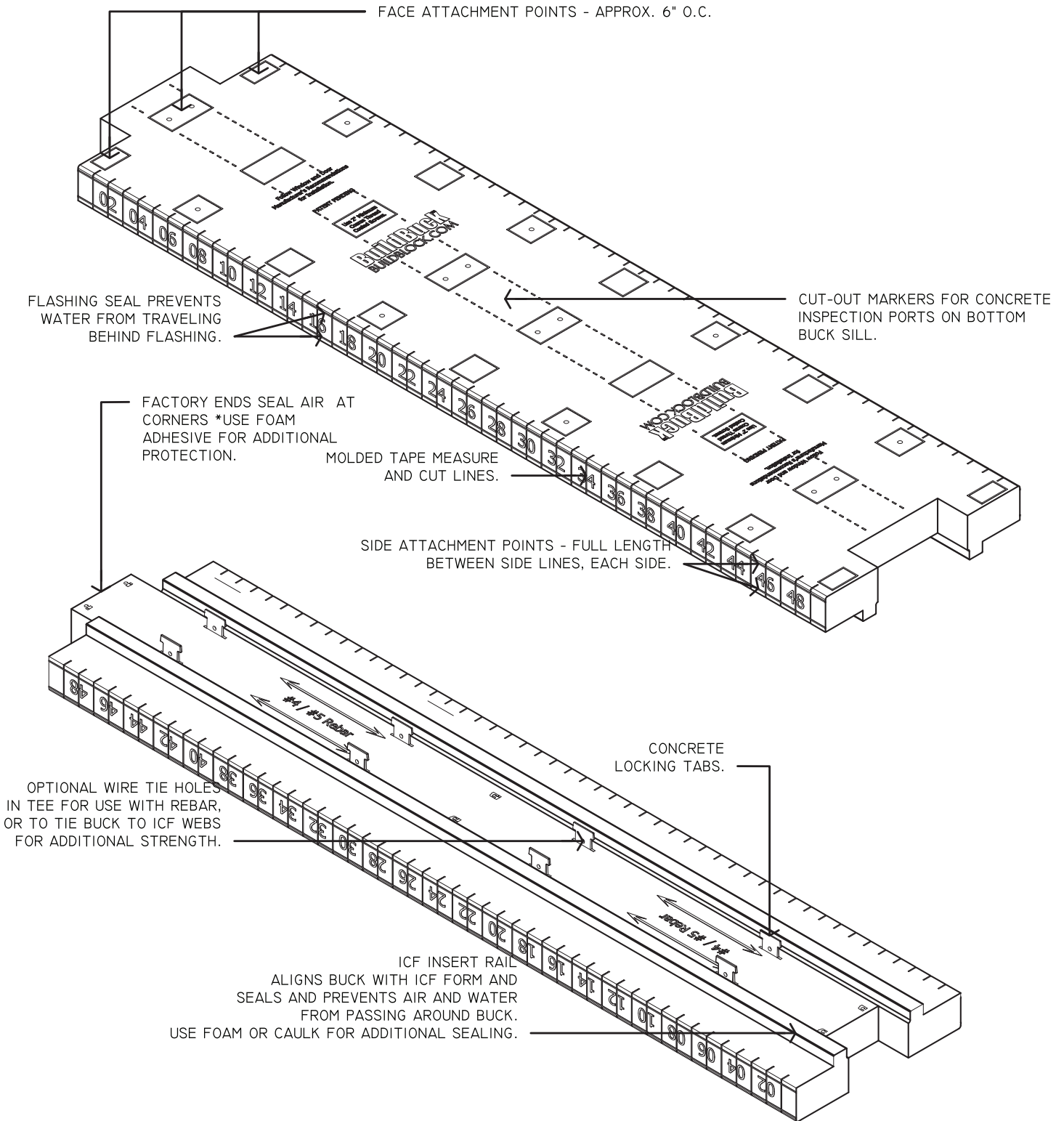

 <p>9705 N. BROADWAY EXTENSION, SUITE 200, OKLAHOMA CITY, OK 73114 OFFICE: 405-840-3386 TOLL FREE: 866-222-2575 FAX: 831-597-0792 BUILDBLOCK.COM</p>	BUILDBUCK PRODUCT FEATURES				<h1>62C</h1>	
	DATE/REV	06/2023	SCALE	NTS		DETAIL SHEET
	NOTES	CONSTRUCTION SHALL BE IN ACCORDANCE WITH ALL APPLICABLE LOCAL AND NATIONAL CODES. ALL DRAWINGS ARE SUBJECT TO CHANGE WITHOUT NOTICE.				

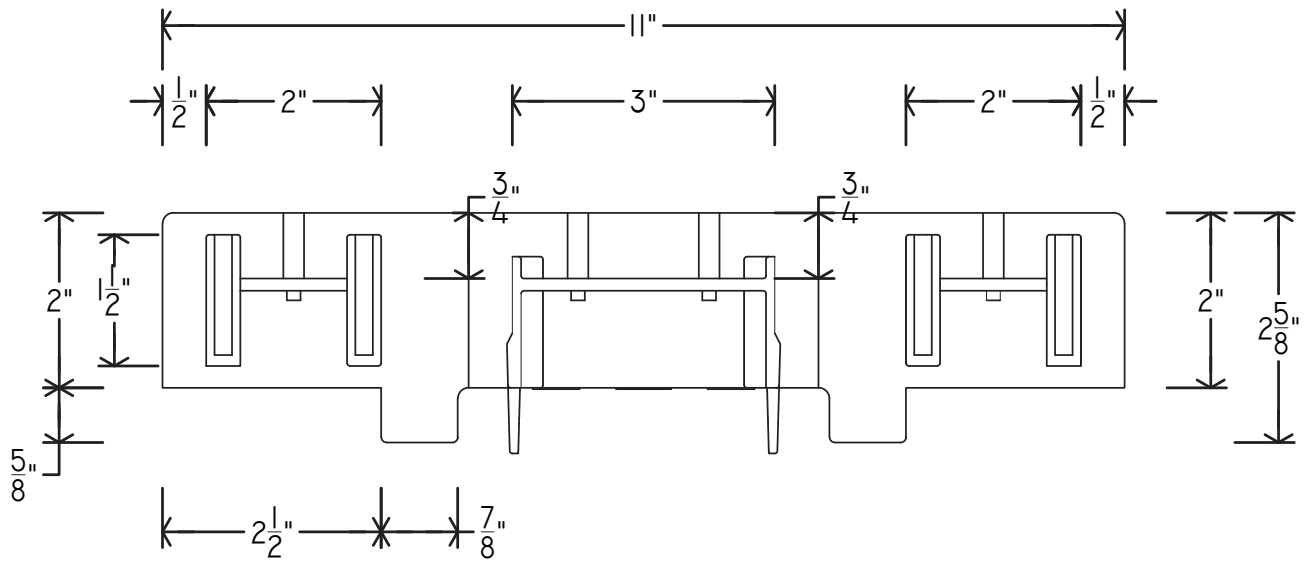

BK-600 6-INCH BUILDBUCK

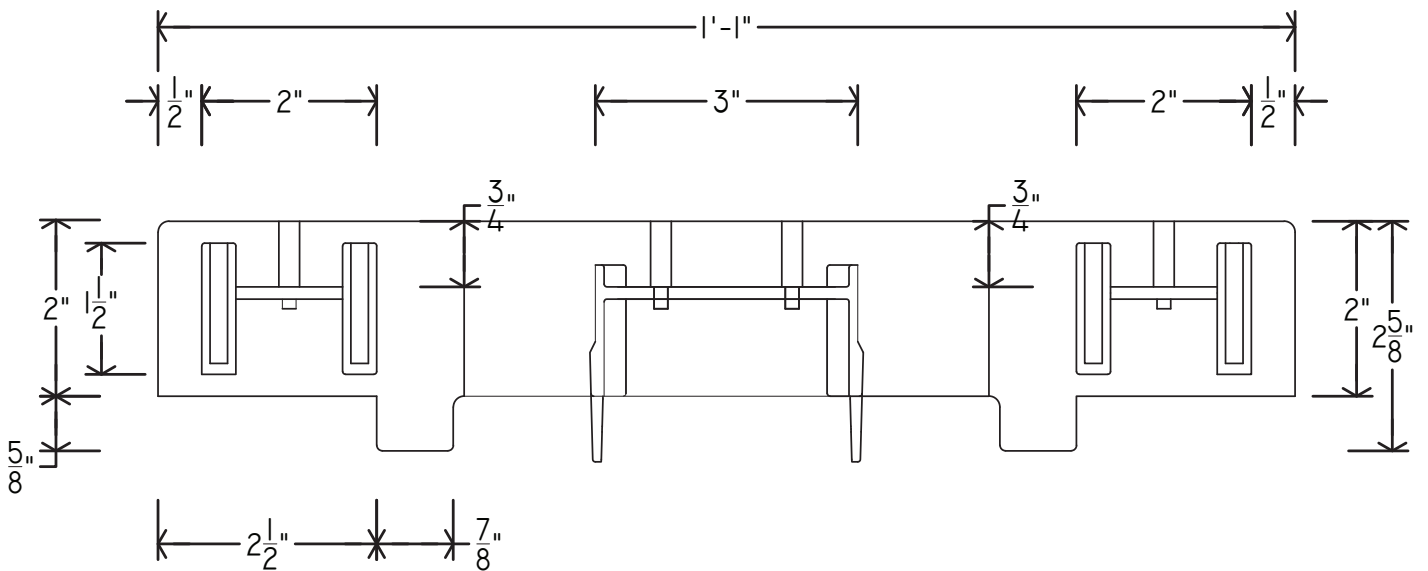

BK-800 8-INCH BUILDBUCK

	BUILDBUCK CROSS SECTIONS BK-600/BK-800		
	DATE/REV 06/2023	SCALE NTS	DETAIL SHEET
	NOTES		62D
9705 N. BROADWAY EXTENSION, SUITE 200, OKLAHOMA CITY, OK 73114 OFFICE: 405-840-3386 TOLL FREE: 866-222-2575 FAX: 831-597-0792 BUILDBLOCK.COM		CONSTRUCTION SHALL BE IN ACCORDANCE WITH ALL APPLICABLE LOCAL AND NATIONAL CODES. ALL DRAWINGS ARE SUBJECT TO CHANGE WITHOUT NOTICE.	

THE DIMENSIONS REPRESENTED BELOW CREATE A FACTORY CONNECTION BETWEEN BUILDBUCK PIECES. WHEN CUTTING BUILDBUCK, IT IS RECOMMENDED TO RE-CUT THE BUILDBUCK PIECES TO RECREATE THE CORRECT FACTORY END AS NEEDED.

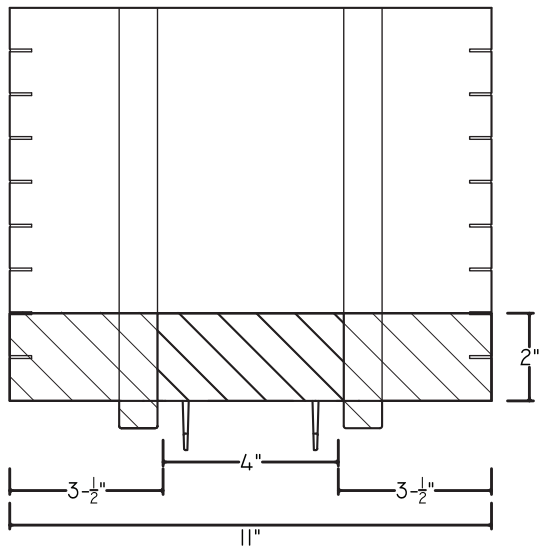

BUILDBUCK CORNER OVERLAP WITH FACTORY EDGE.

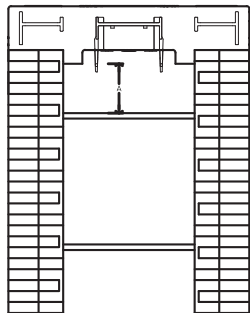

A: WHEN BLOCK IS CUT TO MOLDED VERTICAL CUT LINES, BUILDBUCK WILL CLEAR THE CROSS TIE OF THE WEB. WHEN BLOCK IS CUT THROUGH A WEB VERTICALLY, TRIMMING OF BUILDBUCK MAY BE NECESSARY AS THE BUILDBUCK ALIGNMENT RAILS MAY TOUCH THE WEB FACE.

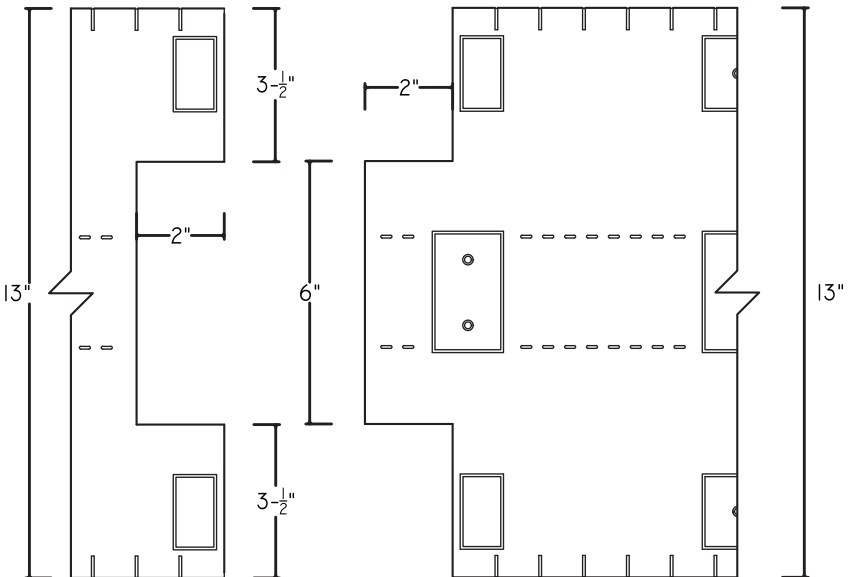
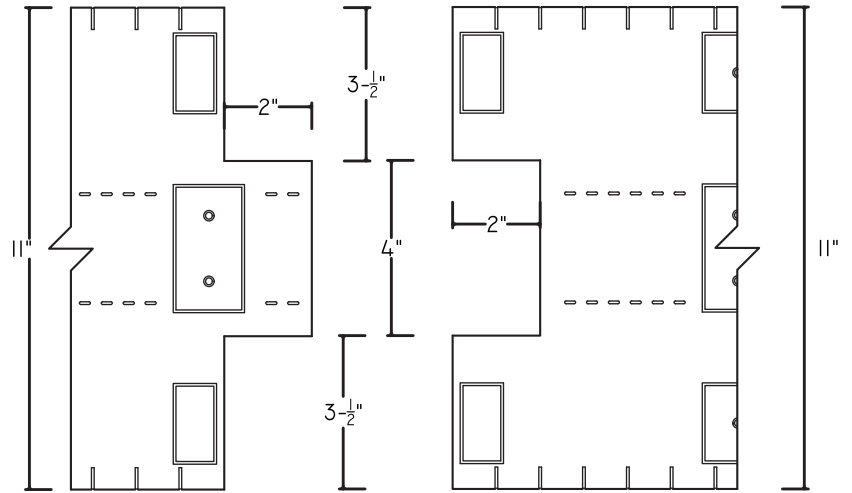

TOP VIEW BUILDBUCK INSTALLED

	BUILDBUCK CONNECTION DETAIL				
	DATE/REV	06/2023	SCALE	NTS	DETAIL SHEET
	NOTES				62E
9705 N. BROADWAY EXTENSION, SUITE 200, OKLAHOMA CITY, OK 73114 OFFICE: 405-840-3386 TOLL FREE: 866-222-2575 FAX: 831-597-0792 BUILDBLOCK.COM		CONSTRUCTION SHALL BE IN ACCORDANCE WITH ALL APPLICABLE LOCAL AND NATIONAL CODES. ALL DRAWINGS ARE SUBJECT TO CHANGE WITHOUT NOTICE.			

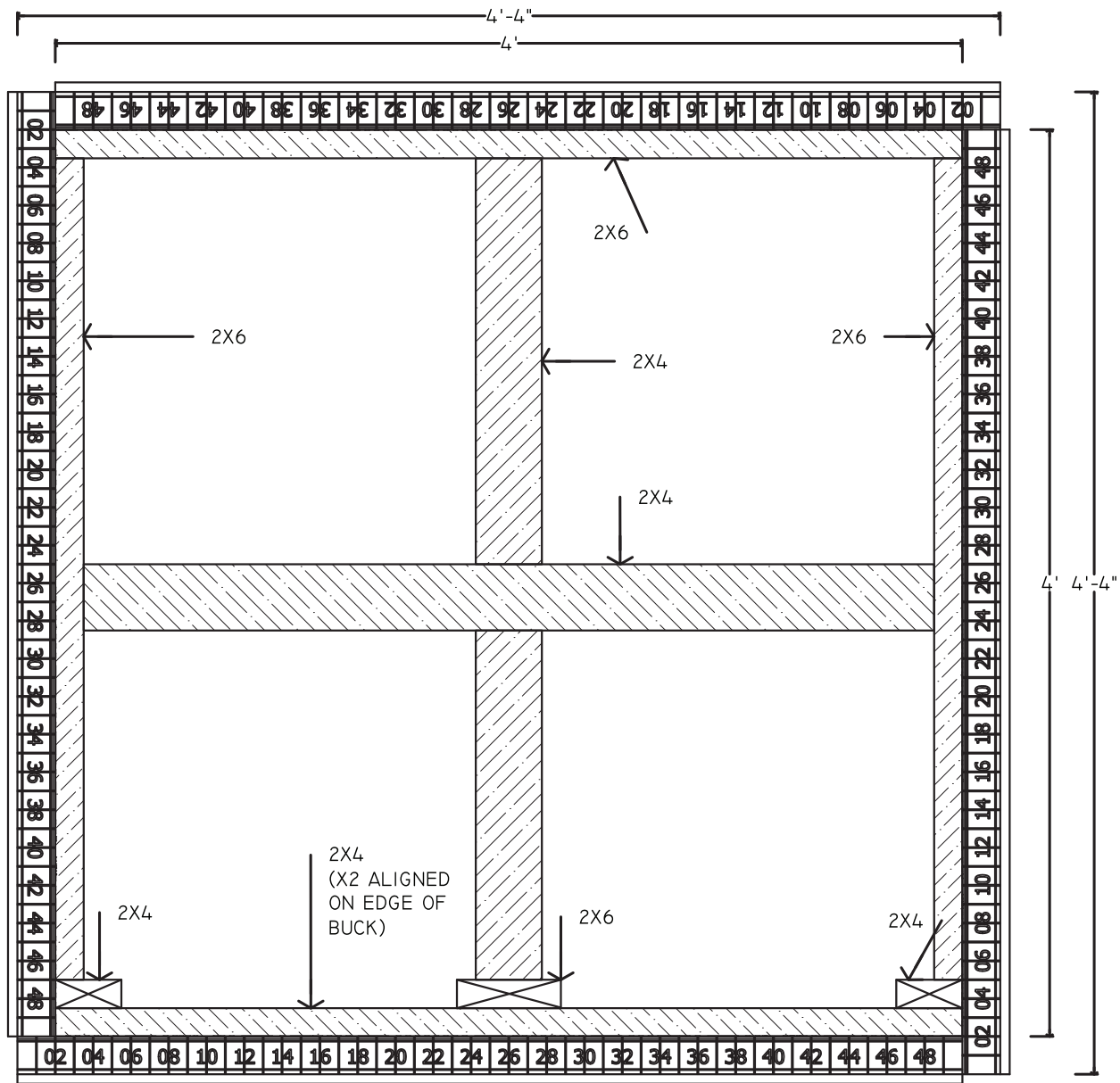

- ☒ MAX OPENING WITH NO SPLICES 48 INCH BY 48 INCH.
- ☒ BUCK OPENING SHOULD BE WINDOW OR DOOR ROUGH OPENING PLUS 4 INCHES OUTSIDE TO OUTSIDE.
- ☒ BUILDBLOCK RECOMMENDS INSTALLING AN INNER FRAME WITH CROSS-BRACES FOR SHORING DURING CONCRETE POUR. VERTICAL BRACING SHOULD REMAIN IN PLACE 7-14 DAYS. IF LOADING LINTELS DURING FRAMING IT IS RECOMMENDED TO LEAVE VERTICAL BRACING IN PLACE AS LONG AS POSSIBLE.
- ☒ OPENINGS WIDER OR TALLER THAN 4FT ARE BUCKED BY JOINING THE BUCK MALE END TO FEMALE END USING THE FACTORY EDGES.
- ☒ CUT BUCKS SHOULD BE TRIMMED TO MAKE A NEW FACTORY EDGE.
- ☒ CORNERS MAY BE JOINED WITH A SIMPLE BUTT JOINT, A FACTORY JOINT OR CUT TO MAKE A FACTORY JOINT.
- ☒ BUCK JOINTS MAY BE BONDED WITH SPRAY FOAM ADHESIVE ON THE JOINING FACES ONLY. USE A MINIMAL AMOUNT. THIS WILL SEAL AGAINST WATER AND AIR INFILTRATION.
- ☒ CORNERS AND OUTER EDGES SHOULD BE FLASHED WITH AN ICF COMPATIBLE FLASHING. TAMKO TW FLASH-N-WRAP OR SIMILAR FLASHING MATERIAL ARE RECOMMENDED. ALTERNATIVELY ALUMINUM HVAC TAPE BONDS TIGHTLY, SEALING ALL JOINTS, AND MAY ALSO BE USED WITH BUILDBUCK.
- ☒ DO NOT USE PETROLEUM BASED CAULKING, SEALANT, OR ADHESIVE.



9705 N. BROADWAY EXTENSION, SUITE 200, OKLAHOMA CITY, OK 73114
 OFFICE: 405-840-3386 | TOLL FREE: 866-222-2575 | FAX: 831-597-0792
 BUILDBLOCK.COM

BUILDBUCK ASSEMBLY AND BRACING

DATE/REV	06/2023	SCALE	NTS	DETAIL SHEET
----------	---------	-------	-----	--------------

NOTES	
-------	--

CONSTRUCTION SHALL BE IN ACCORDANCE WITH ALL APPLICABLE LOCAL AND NATIONAL CODES. ALL DRAWINGS ARE SUBJECT TO CHANGE WITHOUT NOTICE.

62F

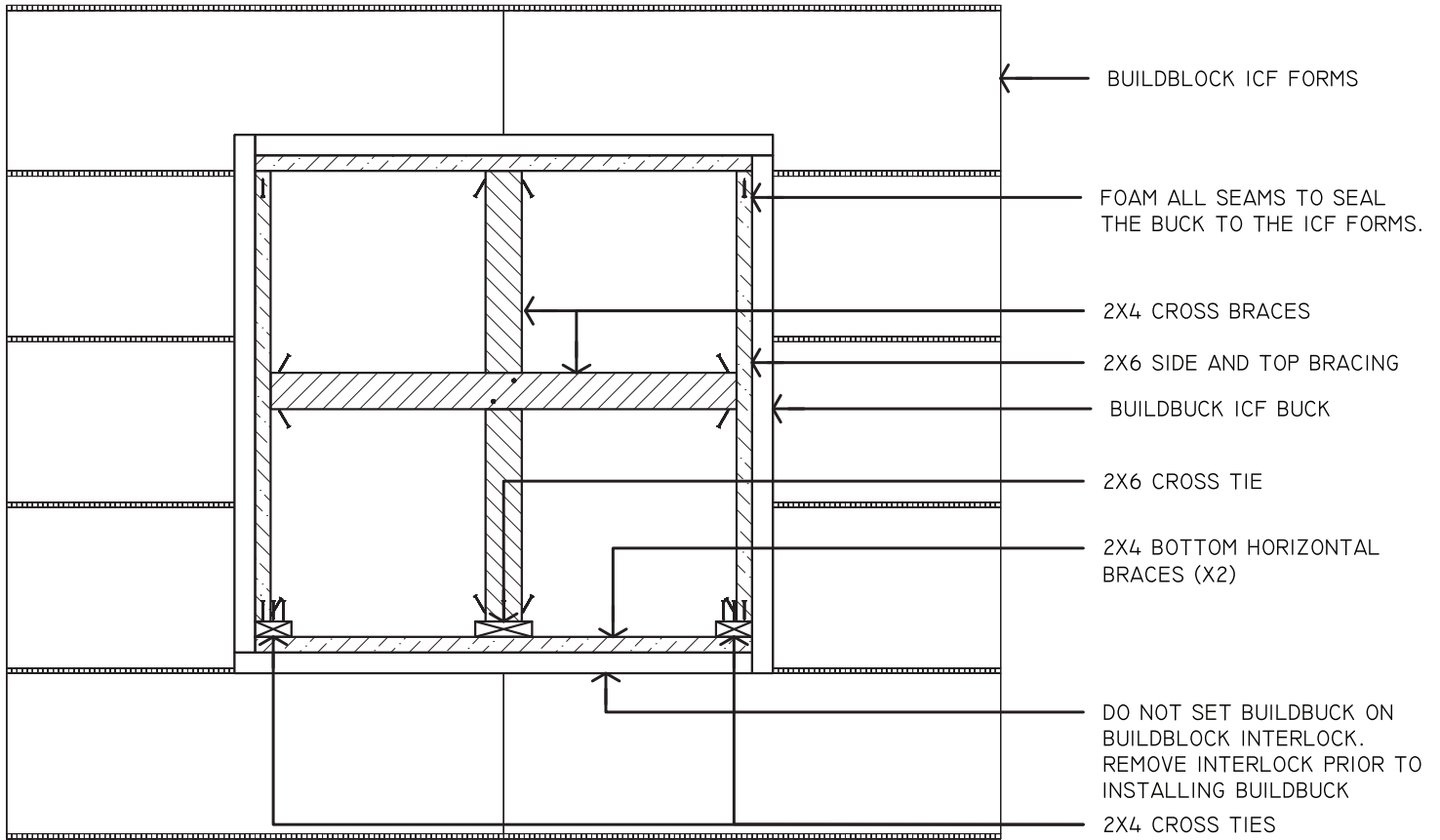

BRACING FOR BUILDBUCK.

1. TOP AND SIDE RAILS - 2X6 LUMBER.
2. BOTTOM RAILS AND CROSS BRACES - 2X4 OR 2X6 LUMBER.
3. BOTTOM CROSS TIES SHOULD BE 2X4 LUMBER ON SIDES AND 2X6 LUMBER IN CENTER.
4. TOP RAIL SHOULD BE CUT FULL ROUGH OPENING WIDTH.
5. BOTTOM RAILS SHOULD BE CUT FULL R/O WIDTH.
6. BOTTOM CROSS TIES SHOULD BE CUT FULL BUCK DEPTH.
7. SIDE RAILS SHOULD BE CUT TO ROUGH OPENING LESS TOP, BOTTOM AND BOTTOM CROSS TIE DIMENSION.
8. ALL RAILS AND CROSS TIES SHOULD BE SCREWED IN THE PATTERN SHOWN. IT IS IMPORTANT TO SCREW THE BOTTOM CROSS TIES AND THE SIDE RAILS TO THE BOTTOM RAILS TO PREVENT THE BUCK FROM SHIFTING DURING THE POUR.
9. CROSS BRACES SHOULD BE 2X4 OR LARGER, AND MAY BE TURNED SO THAT THEY BYPASS AT THE CENTER. THEY SHOULD BE SCREWED TOGETHER AT THE CENTER AND TOENAILED ON EACH END.
10. FOLLOW STANDARD PRACTICES FOR REMOVAL OF BRACING BASED ON LOADS APPLIED AND DESIGN STRENGTH OF CONCRETE.

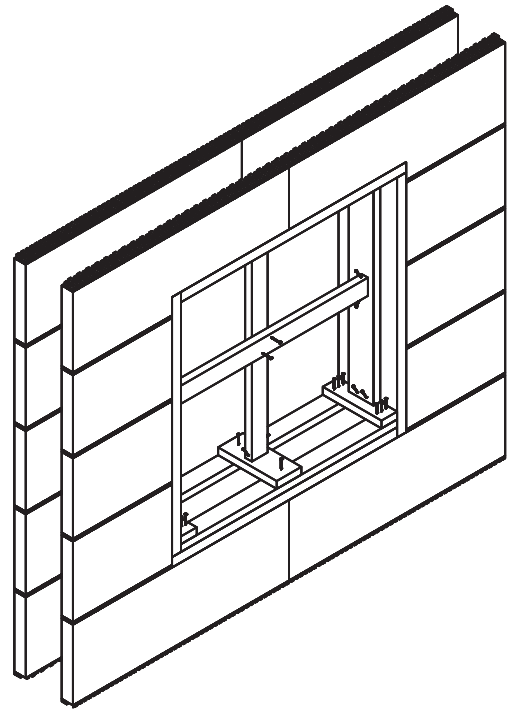

	BUILDBUCK BRACING RECOMMENDATIONS				
	DATE/REV	06/2023	SCALE	NTS	DETAIL SHEET
	NOTES				<h1 style="margin: 0;">62G</h1>
9705 N. BROADWAY EXTENSION, SUITE 200, OKLAHOMA CITY, OK 73114 OFFICE: 405-840-3386 TOLL FREE: 866-222-2575 FAX: 831-597-0792 BUILDBLOCK.COM		CONSTRUCTION SHALL BE IN ACCORDANCE WITH ALL APPLICABLE LOCAL AND NATIONAL CODES. ALL DRAWINGS ARE SUBJECT TO CHANGE WITHOUT NOTICE.			

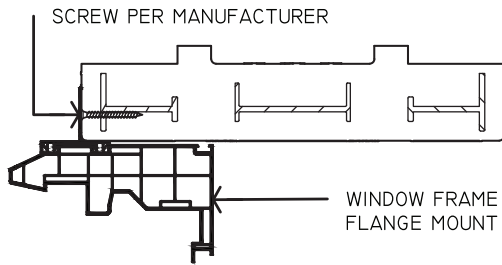

FLANGE MOUNT
(NEW CONSTRUCTION)

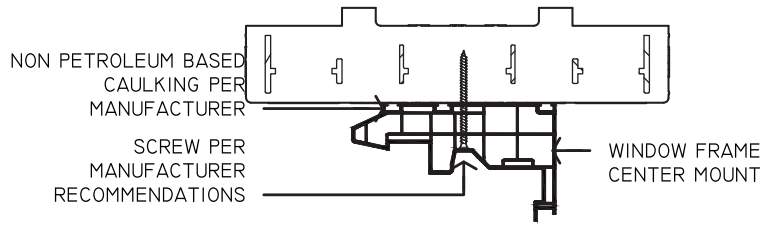

FACE MOUNT
(REPLACEMENT /
COMMERCIAL)

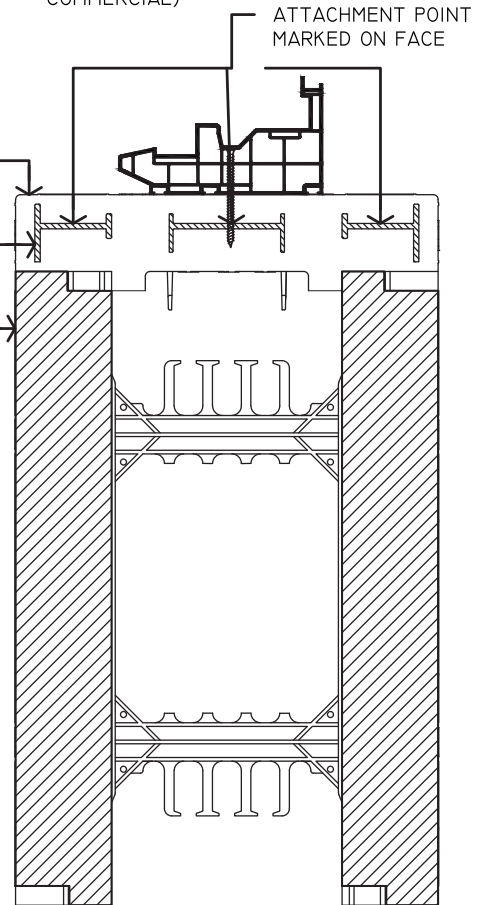
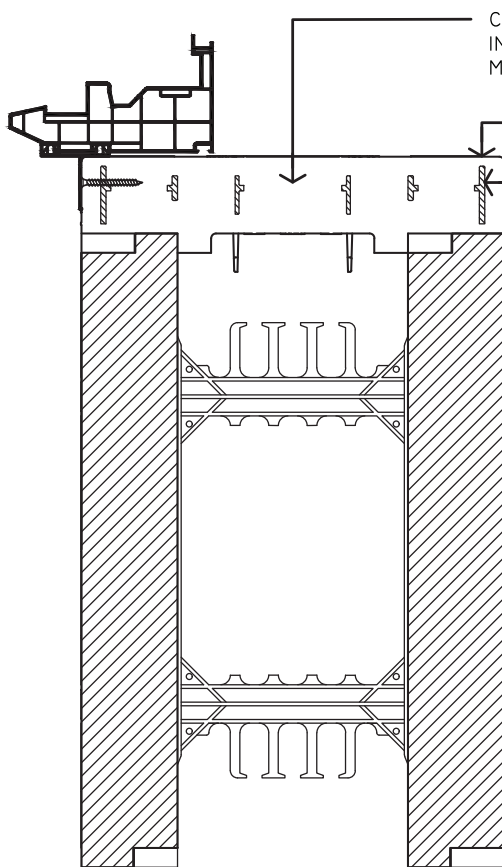

WINDOWS MAY BE INSTALLED EITHER AS A NEW CONSTRUCTION (FLANGED) WINDOW, OR A COMMERCIAL / REPLACEMENT (NON-FLANGED) WINDOW. FLANGED WINDOWS SHOULD BE INSTALLED TO THE OUTSIDE OF THE BUCK, USING THE SIDE ATTACHMENT POINT AS THE NAILER. WINDOWS WITHOUT A FLANGE SHOULD USE THE FACE ATTACHMENT POINTS, WHICH ARE MARKED BY BOUNDING BOXES ON THE FACE OF THE BUCK. USE SCREWS RECOMMENDED BY THE WINDOW MANUFACTURER, AND LONG ENOUGH TO EXTEND 1/2" INTO THE ATTACHMENT POINTS



9705 N. BROADWAY EXTENSION, SUITE 200, OKLAHOMA CITY, OK 73114
OFFICE: 405-840-3386 | TOLL FREE: 866-222-2575 | FAX: 831-597-0792
BUILDBLOCK.COM

BUILDBUCK WINDOW MOUNTING RECOMMENDATIONS

DATE/REV	06/2023	SCALE	NTS	DETAIL SHEET
----------	---------	-------	-----	--------------

NOTES

CONSTRUCTION SHALL BE IN ACCORDANCE WITH ALL APPLICABLE LOCAL AND NATIONAL CODES. ALL DRAWINGS ARE SUBJECT TO CHANGE WITHOUT NOTICE.

62H

SECTION: AA DOOR LINTEL

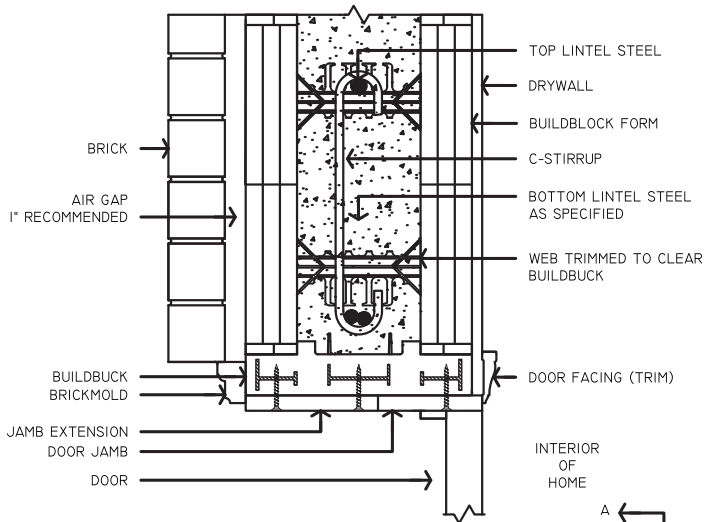

LINTELS (HEADERS ABOVE DOORS AND WINDOWS) SHOULD BE DESIGNED IN ACCORDANCE WITH SITE SPECIFIC ENGINEERING, BUILDBLOCK ENGINEERING MANUAL, PCA-100, THE PRESCRIPTIVE METHOD, OR OTHER APPLICABLE CODES OR ENGINEERING. HORIZONTAL LINTEL STEEL SHOULD EXTEND 2FT PAST EACH SIDE OF AN OPENING FOR BOTH TOP AND BOTTOM BARS. TOP LINTEL BAR IS TYPICALLY THE TOP HORIZONTAL BAR IN THE WALL, AND RUNS FULL LENGTH OF THE WALL IN THE TOP COURSE. "C" OR "S" STIRRUPS ARE USED TO SUPPORT BOTTOM BARS, AND SHOULD EXTEND FROM TOP REBAR TO WITHIN 1" TO 2" OF THE BOTTOM OF THE LINTEL. CENTER DISTANCE OF STIRRUPS IS SPECIFIED IN THE LINTEL TABLES IN THE ENGINEERING SOURCE. MAINTAIN CONCRETE COVERAGE OVER STIRRUPS, MINIMUM 3/4" FROM BACK OF BUCK TO STIRRUP. 1" IS RECOMMENDED.

DOOR INSTALLATION WITH BUILDBUCK:

DUE TO THE THICKNESS OF ICF WALL SYSTEMS, A JAMB EXTENDER OR ADDITIONAL TRIM WILL BE REQUIRED TO FULLY TRIM THE DOOR JAMBS. THESE MAY BE AVAILABLE FROM THE MANUFACTURER, OR BUILT ONSITE BY CONTRACTOR. DOOR MANUFACTURERS MAY HAVE OPTIONS FOR WIDER JAMBS WHEN ORDERING DOORS.

ALL HARDWARE SCREWS MUST BE SIZED TO EXTEND THROUGH THE MOLDED ATTACHMENT POINTS BY 1/2". THESE ARE LOCATED 3/4" BELOW THE FACE OF THE FOAM. ADD 1-1/4" TO THE THICKNESS OF JAMB MATERIAL FOR PROPER SCREW SIZING.

TAPCON OR RED-HEAD FASTENERS MAY BE USED TO FURTHER REINFORCE THE JAMBS, BY EMBEDDING INTO THE CONCRETE CORE OF THE WALL. FOR COMMERCIAL APPLICATIONS, OR HEAVY DUTY INSTALLATIONS, THE CONCRETE INSPECTION WINDOWS ON THE BUCK MAY BE REMOVED PRIOR TO POURING, ALLOWING THE CONCRETE TO FULLY FILL TO THE FACE OF THE BUCK. THIS PROVIDES A MORE DIRECT CONNECTION TO THE CONCRETE CORE, AND ADDITIONAL SUPPORT FOR JAMB MATERIAL. BRACING FOR OPENING SHOULD COVER THESE HOLES, ALLEVIATING THE NEED FOR ADDITIONAL FORMING MATERIAL.

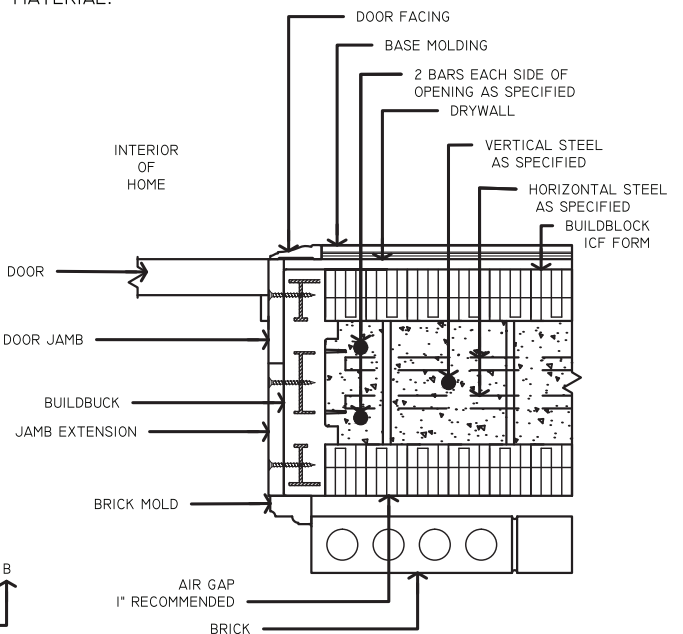
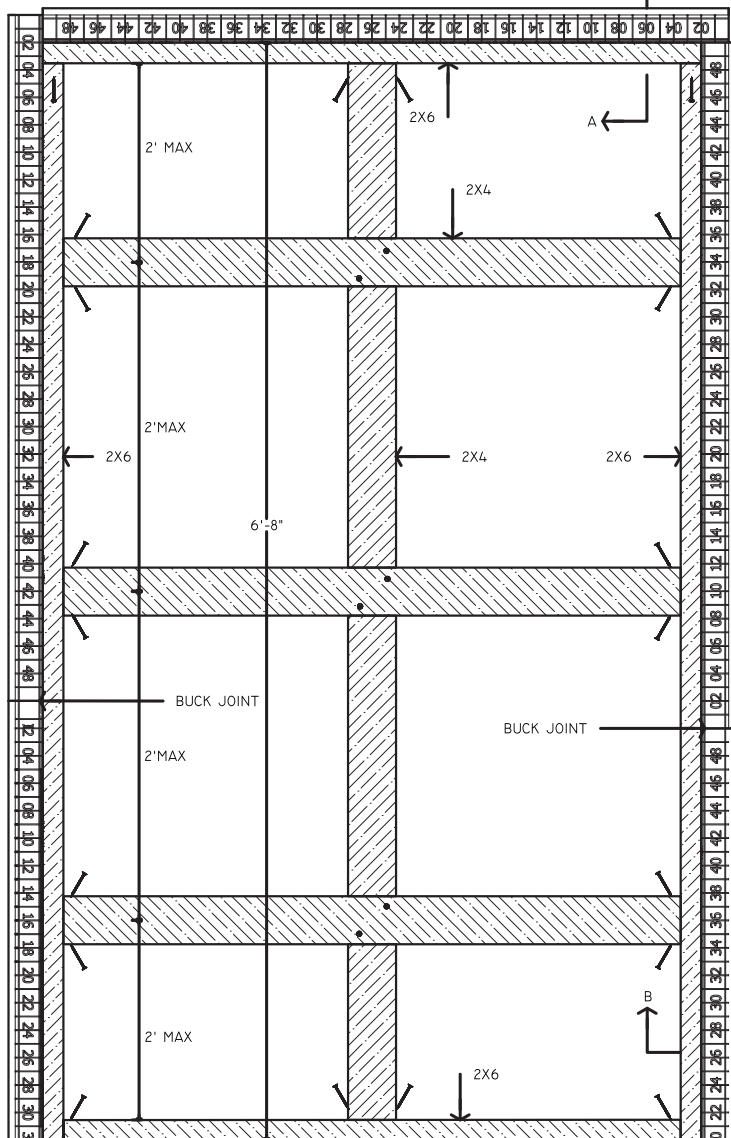

SECTION: BB TOP DOWN VIEW



BUILDBUCK DOOR INSTALLATION DETAIL

DATE/REV	06/2023	SCALE	NTS	DETAIL SHEET
----------	---------	-------	-----	--------------

NOTES	
-------	--

9705 N. BROADWAY EXTENSION, SUITE 200, OKLAHOMA CITY, OK 73114
 OFFICE: 405-840-3386 | TOLL FREE: 866-222-2575 | FAX: 831-597-0792
 BUILDBLOCK.COM

CONSTRUCTION SHALL BE IN ACCORDANCE WITH ALL APPLICABLE LOCAL AND NATIONAL CODES. ALL DRAWINGS ARE SUBJECT TO CHANGE WITHOUT NOTICE.

621



NORTH AMERICAN MANUFACTURING FACILITIES

BuildBlock Building Systems has fourteen manufacturing facilities across North America and plans to add locations for the next several years. This means we have the manufacturing capacity to meet your ICF needs now and in the future. Shorter shipping distances mean lower freight costs for you and your customers.

BuildBlock continually develops new products and technologies solving problems and meeting needs in residential, commercial, industrial, and institutional construction. We innovate with the goal of creating cost-effective techniques and products for our customers.

BuildBlock partners have facilities around the world to meet your needs including the Philippines, Cyprus, and Egypt and continue to expand. Choosing BuildBlock isn't just about choosing the best ICF block on the market, it's about finding a partner with a strong commitment to our customers, our business partners, and our industry.

BuildBlock Building Systems, LLC
9705 N. Broadway Extension, Suite 200
Oklahoma City, OK 73114

866-222-2575 Toll free
405-840-3386 Office
831-597-0792 Fax
buildblock.com
store.buildblock.com

SOCIAL MEDIA



MISSION

We envision a world where BuildBlock ICF technology delivers energy-efficient, safe, healthy, comfortable and sustainable ICF homes and buildings to millions of people worldwide through the uncompromising integrity of BuildBlock's team of distributors, dealers and customers.

VISION

To harmoniously use the extraordinary gifts and talents of our distributors and dealers to fulfill the goals and dreams of millions of people who want to build better structures as reflected by our motto: "Build it once. Build it for life."

To manufacture one of the most affordable and highest quality Insulating Concrete Forms available in the world today.

To build greatness by providing the resources and services needed for building successful ICF businesses and sustainable ICF structures.

To build an enduring, profitable company while conducting business with Godly character, fairness and integrity.

VALUES

INTEGRITY – We strive to balance the best interests of our distributors, dealers, customers, employees, and investors in an environment of Godly character and honesty.

EDUCATION – We seek to educate the public on the valuable benefits of ICF structures while recognizing that in order to expand the industry, we must educate installers, architects, and engineers in ICF best practices.

CUSTOMER SATISFACTION – We commit to building a team of employees that is inspired, empowered, and driven to meet the ever-changing needs of our distributors, dealers, and customers while we seek to distinguish ourselves in the marketplace by delivering exceptional customer satisfaction.

INNOVATION – We value and invest heavily in innovation while continually expanding our product line through the development of technologically advanced products.

QUALITY – We commit to producing the finest quality products. We stand by the belief that our brand embodies quality, consistency, user satisfaction, and service.

PROFITABILITY – We commit to the strong work ethic and financial prudence necessary to deliver financial results for our business partners and investors and to ensure a long-term profitable relationship.

EMPOWERMENT – We dedicate ourselves to empowering people to improve and enrich their lives and the world around them.